

4

3

2

1

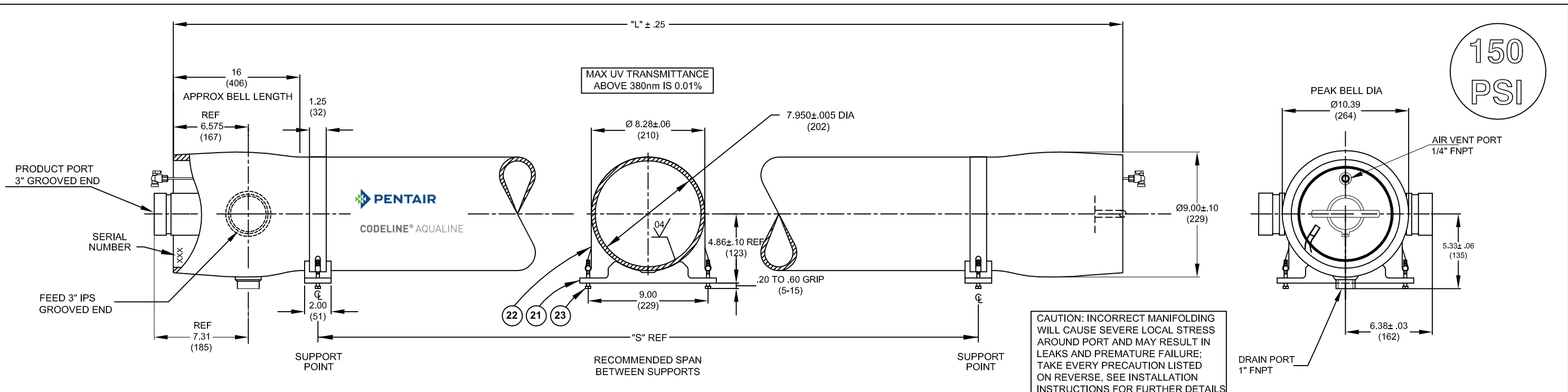

150  
PSI

DWG REF	QTY	PART NUMBER	DESCRIPTION	MATERIAL
<b>SHELL</b>				
1	1	17219	SHELL	Filament Wound Epoxy/Glass composites - Head locking grooves integrally wound in place.
2	A/R	96327	3" Feed Port	SA-995 CD3MWCuN (UNS J93380)
3	A/R	96119	3" Port Seal	Sq. Seal - EPDM
4	1	17180	1" FNPT Drain Port	SA-995 CD3MWCuN (UNS J93380)
5	1	45340	1" Drain Port Seal	Sq. Seal - EPDM
<b>HEAD COMPONENTS FOR 140°F APPLICATION</b>				
6	2	17174	1/4" FNPT Air Vent Port	Engineering Thermoplastic-PVC
7	4	45286	1/4" Air Vent Port Seal	O - Ring - EPDM
8	1	17179	Bearing Plate Handle end	SB-221 A96061-T6
9	1	117007	Sealing Plate Handle end	Engineering Thermoplastic-Noryl
10	1	17176	Bearing Plate Product end	SB-221 A96061-T6
11	1	117006	Sealing Plate Product end	Engineering Thermoplastic-Noryl
12	1	17187	3" Product Port	Engineering Thermoplastic-PVC
13	1	17127	3" Port Retainer Ring	SA-479 316
14	2	96000	Head Seal	O - Ring - EPDM
15	1	17128	Product Port Seal	O - Ring - EPDM
16	1	17104	Handle Assembly	SA-479 316
17	1	45247	Plug Retainer Ring	Stainless Steel
18	1	17132	Plug	Engineering Thermoplastic-PVC
19	1	45312	Plug seal	O - Ring - EPDM
<b>HEAD INTERLOCK</b>				
20	2	47336	Quick Release Spiral Ring	SA-479 316
<b>VESSEL SUPPORT</b>				
21	2	52169	Saddle	Engineering Thermoplastic
22	2	45042	Strap Assy.	304 Stainless Steel-PVC Cushion.
23	4	46265	Strap screw.	5/16-18 UNC X 2.5" Long, 18-8 Stainless Steel.

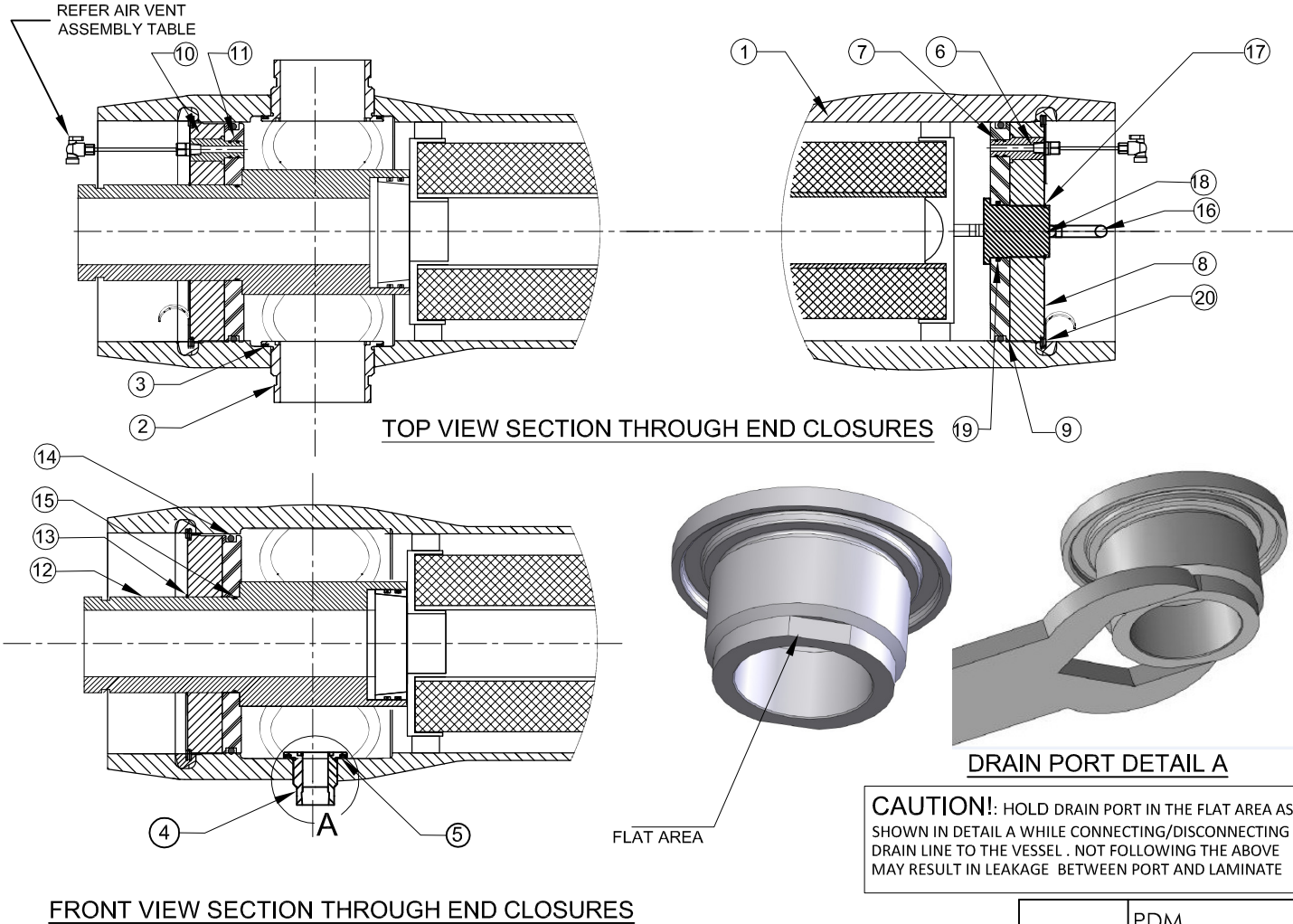

NOTES:-  
 • DIMENSION IN INCHES (MM APPROX.)  
 • SHELL EXTERIOR COATED WITH WHITE, HIGH GLOSS POLYURETHANE PAINT.  
 • NOT TO BE USED FOR CONSTRUCTION UNLESS CERTIFIED.

**AIR VENT ASSEMBLY:-17185**

ITEM	QUANTITY	PART NO.	DESCRIPTION
1	6" Long	RRS-01027	Tubing Blue
2	1	RRS-010013	Male Connector, Pipe 1/4" Tube 1/4"
3	2	RRS-01047	Compression nut 1/4"
4	1	RRS-01039	Ball Valve 1/4"
5	1	17194	Blind Plug 1/4"

Element	"L" IN(MM)	"S" IN(MM)	Approx Weight LB(KG)	Approx Weight With Filter LB(KG)
40	53.94 (1370)	21X1 (533)	51(23)	64(30)

DRAWN	PDM	12MAR14	DATE 04FEB21			DWG. NO. 17046	REV. D
CHECKED	KR	12MAR14	ECN 5572	SCALE NONE	SIZE A3	SHEET 1 OF 2	
APPROVED	SR	12MAR14	MODEL-80CF15-40(NON CODED) SINGLE CATRIDGE HOUSING				

**PENTAIR**  
**CODELINE® AQUALINE**

4

3

2

1

**RATING:**

DESIGN PRESSURE.....150 PSIG  
(1.0MPa)  
 MAX. OPERATING TEMP.....140°F  
(60°C)  
 MIN. OPERATING TEMP..... 20°F  
(-7°C)  
 FACTORY TEST PRESSURE..... 225 PSIG  
(1.55 MPa)  
 QUALIFICATION PRESSURE..... 900 PSI  
(6.2 MPa)

**INTENDED USE:**

The AquaLine 80CF15 Non Coded Fiberglass Pressure Vessel is designed for continuous, long term use as housing for AquaLine range of micro filtration elements.

The Shell of AquaLine 80CF15 Non Coded vessel is designed in accordance with the engineering standards of the Boiler and Pressure Vessel Code of the American Society of Mechanical Engineers (ASME) as per Section X Edition 2019 and all metallic parts are designed as per Section VIII Division I Edition 2019.

The AquaLine 80CF15 Non Coded vessel must be installed, operated and maintained in accordance with the listed precautions and good industrial practice to assure safe operation over a long service life.

The high performance Filament wound FRP shell must be allowed to expand under pressure; undue restraint at support points or piping connections can cause leaks to develop in the shell. This side-ported vessel requires special precautions in mounting and connection to piping so that the vessel will not be subjected to excessive stress due to bending moments acting at the side openings in the fiberglass shell. The end closure, incorporating close fitting, interlocking metal components, must be kept dry and free of corrosion; deterioration can lead to catastrophic mechanical failure of the head.

Pentair will assist the purchaser in determining the suitability of this standard vessel for their specific operating conditions. The final determination however, including evaluation of the standard material of construction for compatibility with the specific corrosive environment, shall be the responsibility of the purchaser. Alternate materials with enhanced corrosion resistance are available on special order.

Specifications are subject to change without notice.

**PRECAUTIONS:**

- DO...read, understand and follow all instructions; failure to take every precaution will void warranty and may result in vessel failure
- DO...mount the shell on horizontal members at span "S" using compliant vessel supports furnished; Shim saddles if required. Tighten hold down straps just snug
- DO...align and center side ports with the manifold header. Correct, causes of misalignment in a row of vessels connected to the same header
- DO...use flexible type IPS grooved-end pipe couplings, or equal, at side ports; allow full, 0.125 inch gap between port and piping, and position piping to maximize flexibility of connection.
- DO...provide flexibility in, and support for piping manifolds so that vessel can grow in length under pressure without undue restraint; provide additional flexible joints in large pipes leading to manifold header.
- DO... Lubricate seals sparingly, using nonpetroleum Based lubricants, i.e. Parker Super O-lube®, Glycerin or suitable silicone based lubricants.
- DO...provide overpressure protection for vessel set at not more than 105% of design pressure
- DO...inspect end closures regularly; replace components that have deteriorated and correct causes of corrosion
- DO NOT...work on any component until first verifying that pressure is relieved from vessel
- DO NOT...make rigid piping connections to ports or clamp vessel in any way that resists growth of fiberglass shell under pressure;
- DO NOT...pressurize vessel until double-checking to verify that the Locking Ring is in place and fully seated.
- DO NOT...operate vessel at pressure and temperature in excess of its rating.
- DO NOT...tolerate leaks or allow end closures to be routinely wetted in any way
- DO NOT...operate outside the pH range of 3-11.

**ORDERING:**

Using the chart below, please check the features you require and fax them with your purchase order to our customer service department for further processing.

For optional materials and / or feature not listed below, please consult the factory for pricing and availability

**VESSEL LENGTH CODE**

**MODEL:** AquaLine 80CF15 Non Coded -40

**CERTIFICATION REQUIRED**

- Standard, Certified by Pentair.
- CE Marked Standard.

**HEAD ASSEMBLY MATERIAL SELECTION**

Engineering Thermoplastic components in PVC as per drawing 17046 on first page.

**FEED PORT CONFIGURATION**

Please tick required configuration below.

- 1A4G (Standard)
- 1A2G (Optional)
- 1A2G4G (Optional)

PORT SIZE CODE	
A	1" FNPT END
G	3" GROOVED END

For complete information on proper use of the vessel  
Please refer to the AquaLine User Guide No 96893.

