

# ELECTRIC VALVE

## ONE STOP SERVICE FOR PIPE EQUIPMENT

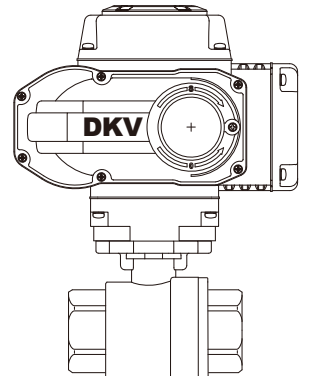
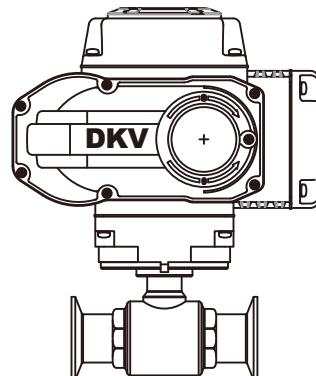
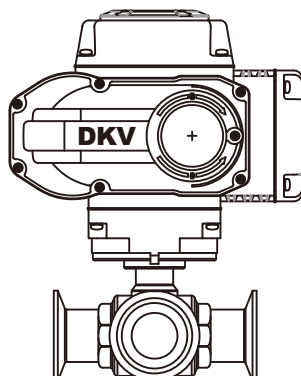
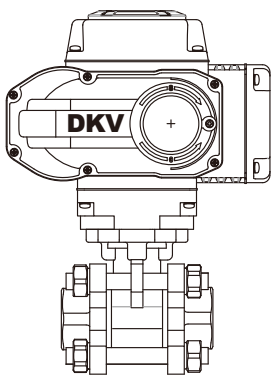

## Introduction

The 2 piece ball valve small size, large diameter, switch easy and convenient, reliable seal, simple structure, easy maintenance, sealing surface and sphere often closed state, not easy to be medium erosion, can be applied to water, gas, steam, oil, nitric acid, acetic acid and other media.

## Electric Actuator

ON/OFF Type	Feedback: the Active Contact Signal, Passive Contact Signal, Resistance, 4-20mA
Regulation Type	Input & Output Signal: DC 4-20mA, DC 0-10V, DC 1-5V
Field Operation	The Field, Remote Control Switch Regulation and MODBUS, PROFIBUS Field Bus
Voltage Optional	AC110-240V 380V 50/60HZ; DC12V, DC24V, Special Voltage Can be Customized
Protection Class	Ip65; Explosion Proof Construction Are Available: EX d II BT4



## Technical Parameters

Body		Valve components	
Size Range	DN05-DN100	Seating Material	PTFE:-20 C~180 C PPL:-20 C~150 C
Body material	SS304SS316 SS316L	Core Material	Stainless Steel
End Connection	Female Thread	Stem Material	Stainless Steel
Operating Pressure	PN1.6MPa	Applicable media	Control of Water, Air, Gas, Oil, Liquid, Steam
Structure	Floating ball core		

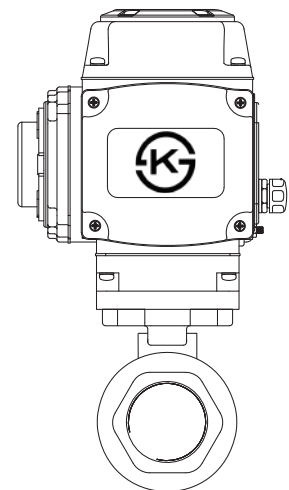

## Qutine Size drawing

UNIT: mm

MEDLE	DK 05	DK10	DK 15	DK 20	DK 25	DK 32	DK 40	DK 50	DK 65	DK80	DK100
G	1/4"	3/8"	1/2"	3/4"	1"	1-1/4"	1-1/2"	2"	2-1/2"	3"	4"
D	5	10	15	20	25	32	40	50	65	80	100
L	55	55	55	73	84	98	106	121	160	180	220
H	30	30	37	40	49	53	62	70	93	106	126

## Installation Instruction

1. Verify that the valve breakaway torque is less than the rated output torque of the actuator.
2. Any mechanical stops that would interfere with the operation of the actuator must be removed before installation of the actuator, i.e. lever, travel stops, etc.
3. The actuator output coupling must be centered with the valve stem to prevent side loading, which causes premature stem packing wear.
4. To use the manual override feature (identified on cover label), the override shaft must be pressed down firmly at least 1/4" in order to disengage the motor from the gears. The manual override is not designed to overcome torque in excess of the rated torque of the actuator. Serious damage to the gear system may result from excessive turning force on the manual override.
5. This Series actuator may be mounted in any position, i.e. horizontal, upside down. If the conduit entrance points upward, conduit piping must be oriented as to prevent condensation from entering the actuator from the conduit pipe.

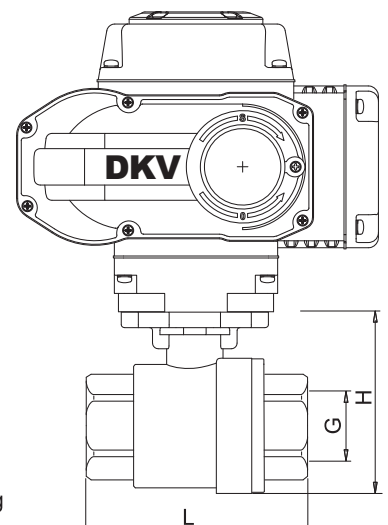

## Introduction

The 3 piece design allows for the center part of the valve containing the ball, stem & seats to be easily removed from the pipeline. This facilitates efficient cleaning of deposited sediments, replacement of seats and gland packings, polishing out of small scratches on the ball, all this without removing the pipes from the valve body. The design concept of a three piece valve is for it to be repairable.

## Electric Actuator

ON/OFF Type	Feedback: the Active Contact Signal, Passive Contact Signal, Resistance, 4-20mA
Regulation Type	Input & Output Signal: DC 4-20mA, DC 0-10V, DC 1-5V
Field Operation	The Field, Remote Control Switch Regulation and MODBUS, PROFIBUS Field Bus
Voltage Optional	AC110-240V 380V 50/60HZ; DC12V, DC24V, Special Voltage Can be Customized
Protection Class	Ip65; Explosion Proof Construction Are Aailable: EX d II BT4

## Technical Parameters

Body		Valve components	
Nominal size	DK08-DK100	Seat material	PTFE:-20 C ~180 C PPL:-20 C ~250 C
Body material	SS304SS316 SS316L	Core material	SS304 SS316
Connection type	Female Thread	Stem material	SS304
Pressure Rating	PN1.0,2.5,4.0,6.4,31.5MPa	Applicable media	Water, Liquids, Gas, Oil, Powder, Steam, Acid-base Corrosive Medium.
Structure type	Floating ball core		

## Qutine Size drawing

UNIT: mm

MEDLE	DK 05	DK 10	DK 15	DK 20	DK 25	DK 32	DK 40	DK 50	DK 65	DK 80	DK100
Actuator	DKV -05							DKV -10	DKV-16	DKV-30	
G	1/4"	3/8"	1/2"	3/4"	1"	1-1/4"	1-1/2"	2"	2-1/2"	3"	4"
D	11.2	12.5	15	20	25	32	40	50	65	80	100
L	60	60	72	82	90	112	120	145	185	210	268
H	42	42	42	48.5	58.5	63	71	78	100	109	140
Weight (Kg)	3.8	3.8	3.8	3.8	4.1	4.5	5.0	5.7	10.1	14.6	19.8

## Installation Instruction

1. Verify that the valve breakaway torque is less than the rated output torque of the actuator.
2. Any mechanical stops that would interfere with the operation of the actuator must be removed before installation of the actuator, i.e. lever, travel stops, etc.
3. The actuator output coupling must be centered with the valve stem to prevent side loading, which causes premature stem packing wear.
4. To use the manual override feature (identified on cover label), the override shaft must be pressed down firmly at least 1/4" in order to disengage the motor from the gears. The manual override is not designed to overcome torque in excess of the rated torque of the actuator. Serious damage to the gear system may result from excessive turning force on the manual override.
5. This Series actuator may be mounted in any position, i.e. horizontal, upside down. If the conduit entrance points upward, conduit piping must be oriented as to prevent condensation from entering the actuator from the conduit pipe.

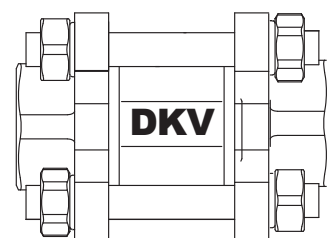
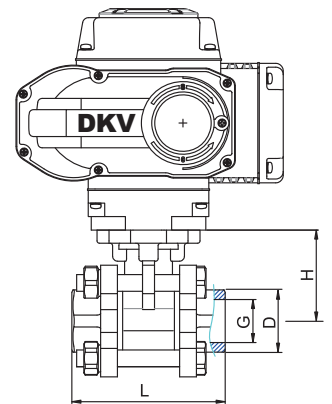
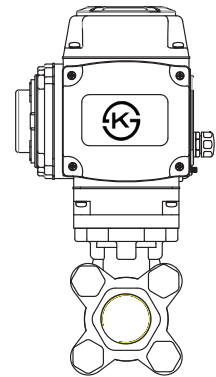

## Introduction

The 3 piece design allows for the center part of the valve containing the ball, stem & seats to be easily removed from the pipeline. This facilitates efficient cleaning of deposited sediments, replacement of seats and gland packings, polishing out of small scratches on the ball, all this without removing the pipes from the valve body. The design concept of a three piece valve is for it to be repairable.



## Electric Actuator

ON/OFF Type	Feedback: the Active Contact Signal, Passive Contact Signal, Resistance, 4-20mA
Regulation Type	Input & Output Signal: DC 4-20mA, DC 0-10V, DC 1-5V
Field Operation	The Field, Remote Control Switch Regulation and MODBUS, PROFIBUS Field Bus
Voltage Optional	AC110-240V 380V 50/60HZ; DC12V, DC24V, Special Voltage Can be Customized
Protection Class	Ip65; Explosion Proof Construction Are Aailable: EX d II BT4

## Technical Parameters

Body		Valve components	
Nominal size	DN08-DN100	Seat material	PTFE:-20℃~180℃ PPL:-20℃~250℃
Body material	SS304SS316 SS316L	Core material	SS304 SS316
Connection type	Clamp	Stem material	SS304
Pressure Rating	PN1.0,2.5,4.0,6.4,31.5MPa	Applicable media	Water, Liquids, Gas, Oil, Powder, Steam, Acid-base Corrosive Medium.
Structure type	Floating ball core		

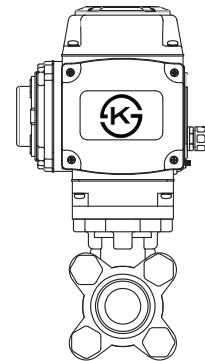

## Qutine Size drawing

UNIT: mm

MEDLE	DK 15	DK 20	DK 25	DK 32	DK 40	DK 50	DK 65	DK 80	DK 100
Actuator	DKV-05				DKV-10			DKV-16	DKV-30
	G	1/2"	3/4"	1"	1-1/4"	1-1/2"	2"	2-1/2"	3"
D	50.5	50.5	50.5	50.5	50.5	64	91	106	119
L	100	100	120	130	140	156	196	228	242
H	55	60	70	82	90	105	120	132	158

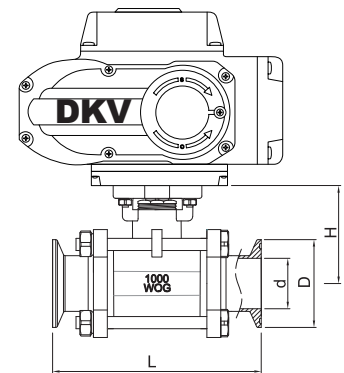

## Installation Instruction

1. Verify that the valve breakaway torque is less than the rated output torque of the actuator.
2. Any mechanical stops that would interfere with the operation of the actuator must be removed before installation of the actuator, i.e. lever, travel stops, etc.
3. The actuator output coupling must be centered with the valve stem to prevent side loading, which causes premature stem packing wear.
4. To use the manual override feature (identified on cover label), the override shaft must be pressed down firmly at least 1/4" in order to disengage the motor from the gears. The manual override is not designed to overcome torque in excess of the rated torque of the actuator. Serious damage to the gear system may result from excessive turning force on the manual override.
5. This Series actuator may be mounted in any position, i.e. horizontal, upside down. If the conduit entrance points upward, conduit piping must be oriented as to prevent condensation from entering the actuator from the conduit pipe.

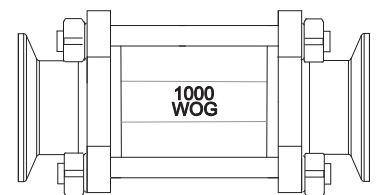

## Introduction

The 3 piece design allows for the center part of the valve containing the ball, stem & seats to be easily removed from the pipeline. This facilitates efficient cleaning of deposited sediments, replacement of seats and gland packings, polishing out of small scratches on the ball, all this without removing the pipes from the valve body. The design concept of a three piece valve is for it to be repairable.

## Electric Actuator

ON/OFF Type	Feedback: the Active Contact Signal, Passive Contact Signal, Resistance, 4-20mA
Regulation Type	Input & Output Signal: DC 4-20mA, DC 0-10V, DC 1-5V
Field Operation	The Field, Remote Control Switch Regulation and MODBUS, PROFIBUS Field Bus
Voltage Optional	AC110-240V 380V 50/60Hz; DC12V, DC24V, Special Voltage Can be Customized
Protection Class	Ip65; Explosion Proof Construction Are Aailable: EX d II BT4



## Technical Parameters

Body		Valve components	
Nominal size	DN08-DN100	Seat material	PTFE: -20°C~180°C PPL: -20°C~250°C
Body material	SS304 SS316 SS316 L	Core material	SS304 SS316
Connection type	Welded	Stem material	SS304
Pressure Rating	PN1.0, 2.5, 4.0, 6.4, 31.5MPa	Applicable medium	Water, Liquids, Gas, Oil, Powder, Steam, Acid-base Corrosive Medium.
Structure type	Floating ball core		

## Qutine Size drawing

UNIT: mm

MEDLE	DN08	DN10	DN15	DN20	DN25	DN32	DN40	DN50	DN65	DN80	DN100
G	1/4"	3/8"	1/2"	3/4"	1"	1-1/4"	1-1/2"	2"	2-1/2"	3"	4"
d	10	12	15	20	25	32	40	50	65	80	100
D	12.5	17.5	22	27	34	42.5	48.5	61	73	90	115
L	65	65	75	83	90	113	115	140	160	180	215
H	33	34	38	45	55	60	70	85	100	112	140

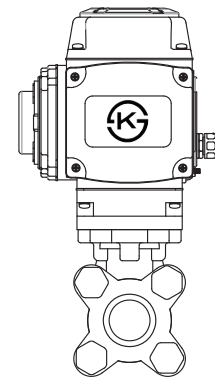

## Installation Instruction

1. Verify that the valve breakaway torque is less than the rated output torque of the actuator.
2. Any mechanical stops that would interfere with the operation of the actuator must be removed before installation of the actuator, i.e. lever, travel stops, etc.
3. The actuator output coupling must be centered with the valve stem to prevent side loading, which causes premature stem packing wear.
4. To use the manual override feature (identified on cover label), the override shaft must be pressed down firmly at least 1/4" in order to disengage the motor from the gears. The manual override is not designed to overcome torque in excess of the rated torque of the actuator. Serious damage to the gear system may result from excessive turning force on the manual override.
5. This Series actuator may be mounted in any position, i.e. horizontal, upside down. If the conduit entrance points upward, conduit piping must be oriented as to prevent condensation from entering the actuator from the conduit pipe.

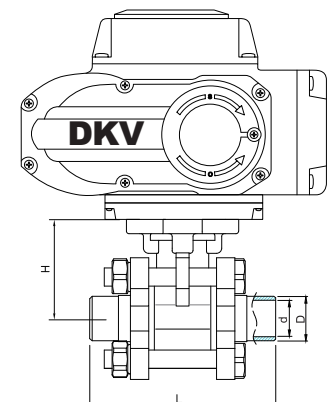

### Introduction

Ultra Low Torque, Elegant, Durable, Corrosion Resistance Full Flow, PTFE Ball sealing, Low Torque Can Use the Handle Regulating Valve Seat Tightness Released By The Central Section Is Still Intact, Valves. Replaceable To Provide Supplementary Platform Embedded Copper Nut Products Convenient Automatic Actuator



### Electric Actuator

ON/OFF Type	Feedback: the Active Contact Signal, Passive Contact Signal, Resistance, 4-20mA
Regulation Type	Input & Output Signal: DC 4-20mA, DC 0-10V, DC 1-5V
Field Operation	The Field, Remote Control Switch Regulation and MODBUS, PROFIBUS Field Bus
Voltage Optional	AC110-240V 380V 50/60Hz; DC12V, DC24V, Special Voltage Can be Customized
Protection Class	Ip67; Explosion Proof Construction Are Aailable: EX d II BT4

### Technical Parameters

Body		Valve components	
Nominal Size	DN15~DN200	Seat Material	PTFE: -30°C~180°C
Body Material	SS304, SS316, SS316L		PPL: -30°C ~ 250°C
Connection Type	Flange	Disc Material	SS304, SS316, SS316L
Pressure Rating	PN1.6~PN6.3MPa	Stem Material	SS304,
Structure type	Floating ball core	Applicable Medium	Water, Liquids, Gas, Oil, Powder, Steam, Acid-base Corrosive Medium.

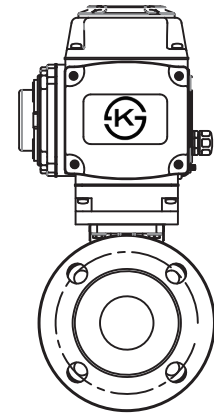

### Qutine Size drawing( ANSI 150#)

UNIT: mm

MEDLE	DN15	DN20	DN25	DN32	DN40	DN50	DN65	DN80	DN100	DN125	DN150	DN200
G	1/2"	3/4"	1"	1-1/4"	1-1/2"	2"	2-1/2"	3"	4"	5"	6"	8"
D3	15	20	25	30	40	50	65	80	100	125	150	200
D2	34.9	42.9	50.8	63.5	73	92.1	104.8	127	157.2	185.7	215.9	269.9
D1	60.3	69.9	79.4	88.9	98.4	120.7	139.7	152.4	190.5	215.9	241.3	298.5
D	90	100	110	115	125	150	180	190	230	255	280	345
L	108	117	127	140	165	178	190	203	229	356	394	457
b	11.5	13	14.5	16	17.5	19.5	22.5	24	24	24	25.5	29
n-φd	4-φ14	4-φ14	4-φ14	4-φ18	4-φ18	4-φ18	4-φ18	8-φ18	8-φ18	8-φ18	8-φ28	4-φ23
Actuator	DKV-05					DKV-10	DKV-16	DKV-30		DKV-60	DKV-125	

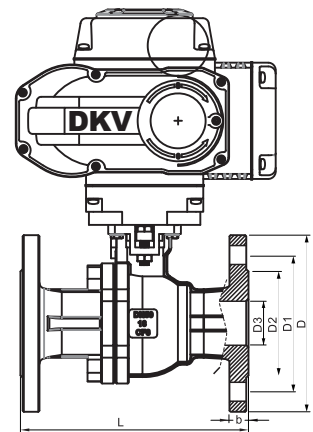

### Installation Instruction

1. Verify that the valve breakaway torque is less than the rated output torque of the actuator.
2. Any mechanical stops that would interfere with the operation of the actuator must be removed before installation of the actuator, i.e. lever, travel stops, etc.
3. The actuator output coupling must be centered with the valve stem to prevent side loading, which causes premature stem packing wear.
4. To use the manual override feature (identified on cover label), the override shaft must be pressed down firmly at least 1/4" in order to disengage the motor from the gears. The manual override is not designed to overcome torque in excess of the rated torque of the actuator. Serious damage to the gear system may result from excessive turning force on the manual override.
5. This Series actuator may be mounted in any position, i.e. horizontal, upside down. If the conduit entrance points upward, conduit piping must be oriented as to prevent condensation from entering the actuator from the conduit pipe.

### Introduction

Fluorine lined ball valve is in the conventional ball valve and ball Structure lined with teflon, so that the media and valve body isolation, antiseptic effect. The valve has more and more close closure function, sealing performance is reliable. Applicable to any concentration of acid, alkali, salt and oxidative extrusion, reducing agent, organic solvents and other media.

### Electric Actuator

ON/OFF Type	Feedback: the Active Contact Signal, Passive Contact Signal, Resistance, 4-20mA
Regulation Type	Input & Output Signal: DC 4-20mA, DC 0-10V, DC 1-5V
Field Operation	The Field, Remote Control Switch Regulation and MODBUS, PROFIBUS Field Bus
Voltage Optional	AC110-240V 380V 50/60Hz; DC12V, DC24V, Special Voltage Can be Customized
Protection Class	Ip65; Explosion Proof Construction Are Available: EX d II BT4

### Technical Parameters

Body		Valve components	
Nominal Size	DN15~DN200	Seat Material	PTFE: -30°C~180°C
Body Material	Castiron	Disc Material	Castiron
Connection Type	Flange	Stem Material	Stainless Steel
Pressure Rating	PN1.0MPa	Applicable Medium	Control of Water, Air, Gas, Oil, Liquid, Steam
Structure type	Floating ball core		

### Qutine Size drawing

UNIT: mm

MEDLE	DN15	DN20	DN25	DN32	DN40	DN50	DN65	DN80	DN100	DN125	DN150	DN200
G	1/2"	3/4"	1"	1-1/4"	1-1/2"	2"	2-1/2"	3"	4"	5"	6"	8"
D3	15	20	25	30	40	50	65	80	100	125	150	200
D2	45	55	65	78	85	100	120	135	155	185	210	265
D1	65	75	85	100	110	125	145	160	180	210	240	295
D	95	105	115	135	145	160	180	195	215	245	280	335
L	140	140	150	165	180	200	220	250	280	320	360	400
b	14	16	16	18	18	20	20	22	22	24	24	26
n-φd	4-φ14	4-φ14	4-φ14	4-φ18	4-φ18	4-φ18	4-φ18	8-φ18	8-φ18	8-φ18	8-φ28	8-φ23

### Installation Instruction

1. Verify that the valve breakaway torque is less than the rated output torque of the actuator.
2. Any mechanical stops that would interfere with the operation of the actuator must be removed before installation of the actuator, i.e. lever, travel stops, etc.
3. The actuator output coupling must be centered with the valve stem to prevent side loading, which causes premature stem packing wear.
4. To use the manual override feature (identified on cover label), the override shaft must be pressed down firmly at least 1/4" in order to disengage the motor from the gears. The manual override is not designed to overcome torque in excess of the rated torque of the actuator. Serious damage to the gear system may result from excessive turning force on the manual override.
5. This Series actuator may be mounted in any position, i.e. horizontal, upside down. If the conduit entrance points upward, conduit piping must be oriented as to prevent condensation from entering the actuator from the conduit pipe.

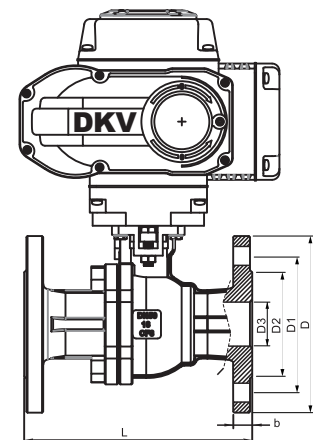
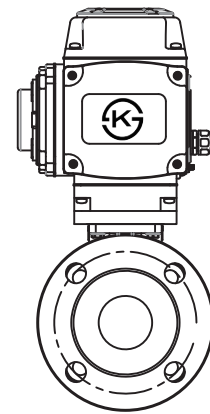

## Introduction

Ultra Low Torque, Elegant, Durable, Corrosion Resistance Full Flow, PTFE Ball sealing, Low Torque Can Use the Handle Regulating Valve Seat Tightness Released By The Central Section Is Still Intact, Valves. Replaceable To Provide Supplementary Platform Embedded Copper Nut Products Convenient Automatic Actuator



## Electric Actuator

ON/OFF Type	Feedback: the Active Contact Signal, Passive Contact Signal, Resistance, 4-20mA
Regulation Type	Input & Output Signal: DC 4-20mA, DC 0-10V, DC 1-5V
Field Operation	The Field, Remote Control Switch Regulation and MODBUS, PROFIBUS Field Bus
Voltage Optional	AC110-240V 380V 50/60Hz; DC12V, DC24V, Special Voltage Can be Customized
Protection Class	Ip65; Explosion Proof Construction Are Available: EX d II BT4

## Technical Parameters

Body		Valve components	
Nominal Size	DN15~DN200	Seat Material	PTFE: -30°C~180°C
Body Material	SS304, SS316, SS316L		PPL: -30°C ~ 250°C
Connection Type	Flange	Disc Material	SS304, SS316, SS316L
Pressure Rating	PN1.6~PN6.3MPa	Stem Material	SS304,
Structure type	Floating ball core	Applicable Medium	Water, Liquids, Gas, Oil, Powder, Steam, Acid-base Corrosive Medium.

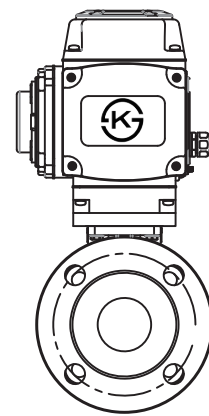

## Qutine Size drawing

UNIT: mm

MEDLE	DN15	DN20	DN25	DN32	DN40	DN50	DN65	DN80	DN100	DN125	DN150	DN200
G	1/2"	3/4"	1"	1-1/4"	1-1/2"	2"	2-1/2"	3"	4"	5"	6"	8"
D3	15	20	25	30	40	50	65	80	100	125	150	200
D2	45	55	65	78	85	100	120	135	155	185	210	265
D1	65	75	85	100	110	125	145	160	180	210	240	295
D	95	105	115	135	145	160	180	195	215	245	280	335
L	130	140	150	165	180	200	222	250	280	320	360	400
n-φd	4-φ14	4-φ14	4-φ14	4-φ18	4-φ18	4-φ18	4-φ18	8-φ18	8-φ18	8-φ18	8-φ28	4-φ23
Weight (Kg)	5.4	5.7	6.1	7.4	8.7	11.6	15.6	17.1	24.98	33.5	43.5	
Actuator	DKV-05			DKV-10		DKV-16		DKV-30		DKV-60		DKV-125

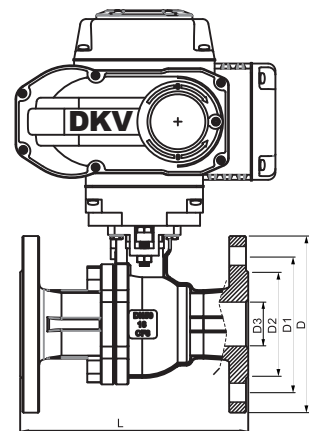

## Installation Instruction

1. Verify that the valve breakaway torque is less than the rated output torque of the actuator.
2. Any mechanical stops that would interfere with the operation of the actuator must be removed before installation of the actuator, i.e. lever, travel stops, etc.
3. The actuator output coupling must be centered with the valve stem to prevent side loading, which causes premature stem packing wear.
4. To use the manual override feature (identified on cover label), the override shaft must be pressed down firmly at least 1/4" in order to disengage the motor from the gears. The manual override is not designed to overcome torque in excess of the rated torque of the actuator. Serious damage to the gear system may result from excessive turning force on the manual override.
5. This Series actuator may be mounted in any position, i.e. horizontal, upside down. If the conduit entrance points upward, conduit piping must be oriented as to prevent condensation from entering the actuator from the conduit pipe.

## Introduction

The 3 piece design allows for the center part of the valve containing the ball, stem & seats to be easily removed from the pipeline. This facilitates efficient cleaning of deposited sediments, replacement of seats and gland packings, polishing out of small scratches on the ball, all this without removing the pipes from the valve body. The design concept of a three piece valve is for it to be repairable.

## Electric Actuator

ON/OFF Type	Feedback: the Active Contact Signal, Passive Contact Signal, Resistance, 4-20mA
Regulation Type	Input & Output Signal: DC 4-20mA, DC 0-10V, DC 1-5V
Field Operation	The Field, Remote Control Switch Regulation and MODBUS, PROFIBUS Field Bus
Voltage Optional	AC110~240V 380V 50/60Hz; DC12V, DC24V, Special Voltage Can be Customized
Protection Class	Ip65; Explosion Proof Construction Are Aailable: EX d II BT4



## Technical Parameters

Body		Valve components	
Nominal Size	DN15~DN100	Seat Material	PTFE: -30°C ~180°C PPL: -30°C ~250°C
Body Material	SS304, SS316, SS316L	Disc Material	SS304, SS316, SS316L
Connection Type	Clamp, Welding	Stem Material	SS304,
Pressure Rating	PN1.6MPa	Design Standard	ISO、DIN、IDF、SMS、3A
Structure type	Floating ball core 3 way L-type/ T-type ball valve	Applicable Medium	Food, Medicine, Packaging Machinery, Filling Machinery And Other Health Conditions Using Level.

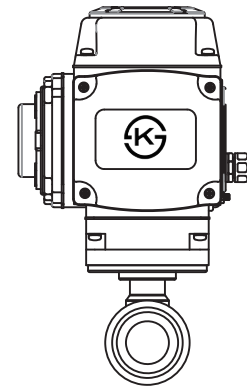

## Qutine Size drawing

UNIT: mm

Size	Ø19	Ø25	Ø32	Ø38	Ø51	Ø63	Ø76	Ø89	Ø102
DN	DN15	DN20	DN25	DN32	DN40	DN50	DN65	DN80	DN100
d	16	21	29	35	47	59	72	85	97
D	50.5	50.5	50.5	50.5	64	77.5	91	106	119
L	102	117	123	140	180	200	220	235	275
Actuator	DKV-05					DKV-10		DKV-16	
Weight (kg)	3.8	3.9	3.95	4.3	5.1	7.3	8.8	11.4	13.5

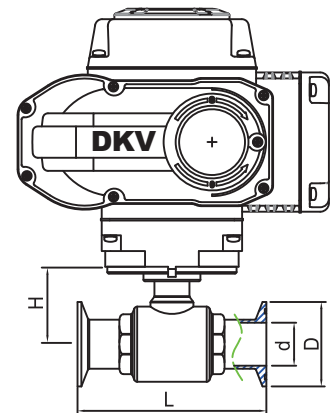

## Installation Instruction

1. Verify that the valve breakaway torque is less than the rated output torque of the actuator.
2. Any mechanical stops that would interfere with the operation of the actuator must be removed before installation of the actuator, i.e. lever, travel stops, etc.
3. The actuator output coupling must be centered with the valve stem to prevent side loading, which causes premature stem packing wear.
4. To use the manual override feature (identified on cover label), the override shaft must be pressed down firmly at least 1/4" in order to disengage the motor from the gears. The manual override is not designed to overcome torque in excess of the rated torque of the actuator. Serious damage to the gear system may result from excessive turning force on the manual override.
5. This Series actuator may be mounted in any position, i.e. horizontal, upside down. If the conduit entrance points upward, conduit piping must be oriented as to prevent condensation from entering the actuator from the conduit pipe.

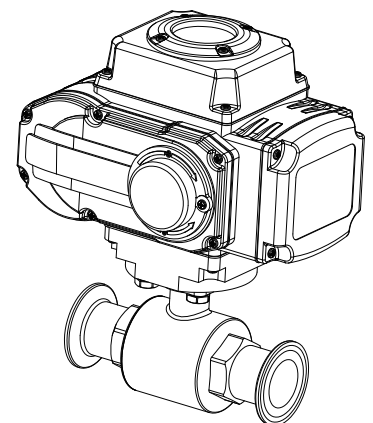

## Introduction

Ultra Low Torque, Elegant. Durable. Corrosion Resistance Full Flow. PTFE Ball sealing. Low Torque Can Use the Handle Regulating Valve Seat Tightness Released By The Central Section Is Still Intact, Valves. Replaceable To Provide Supplementary Platform Embedded Copper Nut Products Convenient Automatic Actuator



## Electric Actuator

ON/OFF Type	Feedback: the Active Contact Signal, Passive Contact Signal, Resistance, 4-20mA
Regulation Type	Input & Output Signal: DC 4-20mA, DC 0-10V, DC 1-5V
Field Operation	The Field, Remote Control Switch Regulation and MODBUS, PROFIBUS Field Bus
Voltage Optional	AC110-240V 380V 50/60HZ; DC12V, DC24V, Special Voltage Can be Customized
Protection Class	Ip65; Explosion Proof Construction Are Available: EX d II BT4

## Technical Parameters

Body		Valve components	
Nominal size	DN15~DN400	Seat material	EPDM
Body material	Plastic UPVC	Core material	Plastic UPVC
Connection type	Double union	Stem material	SS304, SS410
Pressure Rating	PN1.0MPa PN1.6MPa	Applicable Medium	Water, Liquids. Gas, Oil. Powder. Steam. Acid-base Corrosive Medium.
Structure type	Floating ball core		

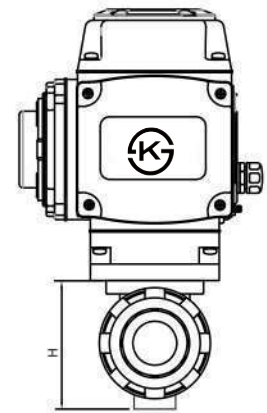

## Qutine Size drawing

MEDLE	DN15	DN20	DN25	DN32	DN40	DN50	DN65	DN80	DN100
G	1/2"	3/4"	1"	1-1/4"	1-1/2"	2"	2-1/2"	3"	4"
d	14	20	25	30	38	50	63	78	100
D	20	25	32	40	50	63	75	90	110
D1	30	36	45	55	64	77	96	112	141
L1	22.8	25	28.5	32	34.8	39	46	48	64.5
L	121.8	134.5	150.2	166.8	179	205	233	257	309
H	61	74	90	104	121	146	169	220	255
Weight (Kg)	3.4	3.5	3.65	3.88	4.6	5.1	7.6	9.4	12.6
Actuator			DKV-05				DKV-10	DKV-16	

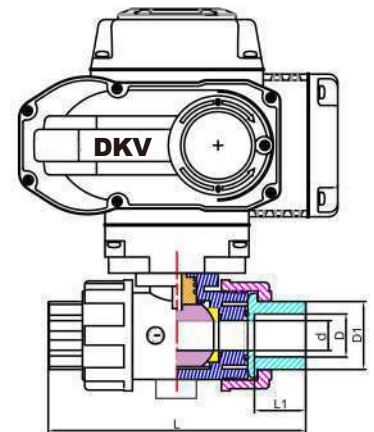

## Installation Instruction

1. Verify that the valve breakaway torque is less than the rated output torque of the actuator.
2. Any mechanical stops that would interfere with the operation of the actuator must be removed before installation of the actuator, i.e. lever, travel stops, etc.
3. The actuator output coupling must be centered with the valve stem to prevent side loading, which causes premature stem packing wear.
4. To use the manual override feature (identified on cover label), the override shaft must be pressed down firmly at least 1/4" in order to disengage the motor from the gears. The manual override is not designed to overcome torque in excess of the rated torque of the actuator. Serious damage to the gear system may result from excessive turning force on the manual override.
5. This Series actuator may be mounted in any position, i.e. horizontal, upside down. If the conduit entrance points upward, conduit piping must be oriented as to prevent condensation from entering the actuator from the conduit pipe.

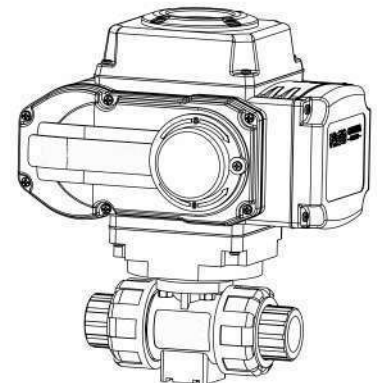

### Introduction

Ultrahigh pressure ball is adopt ball core rotate 90 degrees to open or close the valve, the brick, high pressure forging with German import seal assembly, provided by initial seal, stainless steel butterfly spring cushion packing seal surface enhanced with medium pressure rise, self sealing performance is strong, super high pressure ball valve can be used in the ultra high pressure liquid, ultrahigh pressure gas or the mixture of main application industry has ultrahigh pressure testing machine, pneumatic pumps, hydraulic pump, deep-sea detectors.

### Electric Actuator

ON/OFF Type	Feedback: the Active Contact Signal, Passive Contact Signal, Resistance, 4-20mA
Regulation Type	Input & Output Signal: DC 4-20mA, DC 0-10V, DC 1-5V
Field Operation	The Field, Remote Control Switch Regulation and MODBUS, PROFIBUS Field Bus
Voltage Optional	AC110-240V 380V 50/60Hz; DC12V, DC24V, Special Voltage Can be Customized
Protection Class	Ip65; Explosion Proof Construction Are Aailable: EX d II BT4



### Technical Parameters

Body		Valve components	
Nominal Size	DN15~DN200	Seat Material	PTFE: -30°C~180°C
Body Material	SS304, SS316, SS316L		PPL: -30°C ~ 250°C
Connection Type	Thread	Disc Material	SS304, SS316, SS316L
Pressure Rating	PN1.6~PN6.3MPa	Stem Material	SS304,
Structure type	Floating ball core	Applicable Medium	Water, Liquids, Gas, Oil, Powder, Steam, Acid-base Corrosive Medium.

### Qutine Size drawing

UNIT: mm

MEDLE	DN08	DN10	DN15	DN20	DN25	DN32	DN40	DN50
G	1/4"	3/8"	1/2"	3/4"	1"	1-1/4"	1-1/2"	2"
D	6	8	10	14.6	19.6	24.8	30	39.6
B	33	35	37	45	55	88	102	113
L	69	72	83	95	113	120	131	142
H	13	16	18	24	32	38	42	50
H1	176	176	176	237	237	249	285	348

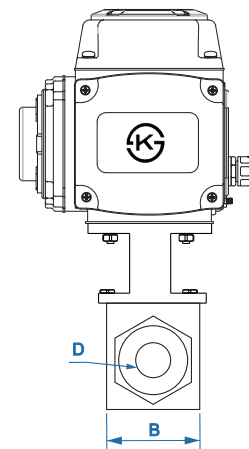

### Installation Instruction

1. Verify that the valve breakaway torque is less than the rated output torque of the actuator.
2. Any mechanical stops that would interfere with the operation of the actuator must be removed before installation of the actuator, i.e. lever, travel stops, etc.
3. The actuator output coupling must be centered with the valve stem to prevent side loading, which causes premature stem packing wear.
4. To use the manual override feature (identified on cover label), the override shaft must be pressed down firmly at least 1/4" in order to disengage the motor from the gears. The manual override is not designed to overcome torque in excess of the rated torque of the actuator. Serious damage to the gear system may result from excessive turning force on the manual override.
5. This Series actuator may be mounted in any position, i.e. horizontal, upside down. If the conduit entrance points upward, conduit piping must be oriented as to prevent condensation from entering the actuator from the conduit pipe.

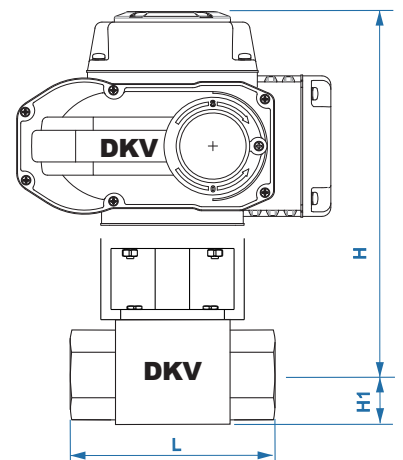

## Introduction

Electric three way ball valve is classified into L type electric three way ball valve and T type electric three way ball valve. L type electric three way ball valve can connect mutually perpendicular two pipelines. T type electric three way ball valve is utilized to divert, interflow and flow reversal.

## Electric Actuator

ON/OFF Type	Feedback: the Active Contact Signal, Passive Contact Signal, Resistance, 4-20mA
Regulation Type	Input & Output Signal: DC 4-20mA, DC 0-10V, DC 1-5V
Field Operation	The Field, Remote Control Switch Regulation and MODBUS, PROFIBUS Field Bus
Voltage Optional	AC110-240V 380V 50/60Hz; DC12V, DC24V, Special Voltage Can be Customized
Protection Class	Ip65; Explosion Proof Construction Are Aailable: EX d II BT4



## Technical Parameters

Valve Body		Valve Components	
Size Range	DN08-DN65	Body Material	Stainless Steel
Operating Pressure	1.0MPa-6.4MPa	Core Material	Stainless Steel
End Connection	Threaded, Butt Welded	Sealing Material	PTFE: -30°C~180°C PPL: -30°C~250°C
Structure	3 Way L-port/ T-port	Applicable Media	Control of Water, Air, Gas, Oil, Liquid, Steam

## Outline Size drawing

UNIT: mm

MEDLE	DN08	DN10	DN15	DN20	DN25	DN32	DN40	DN50	DN65
Actuator	DKV-05					DKV-10		DKV-16	
G	1/4"	3/8"	1/2"	3/4"	1"	1-1/4"	1-1/2"	2"	2-1/2"
D	10	12	12	15	20	25	32	38	48,5
L	71	71	74	88	92	124	138	154	180
H	56	56	58	60	70	82	95	100	180
Weight (Kg)			3.7	3.8	4.1	7.6	8.1	9.3	14..6

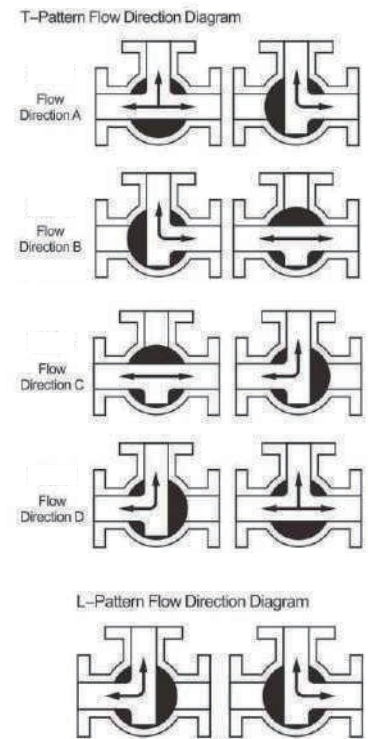

## Installation Instruction

- Before installing the valve, clean the line of dirt, scale, welding chips, and other foreign material. Clean gasket surfaces thoroughly to insure leak-proof joints.
- Verify that the valve breakaway torque is less than the rated output torque of the actuator.
- Any mechanical stops that would interfere with the operation of the actuator must be removed before installation of the actuator, i.e. lever, travel stops, etc.
- The actuator output coupling must be centered with the valve stem to prevent side loading, which causes premature stem packing wear.
- To use the manual override feature (identified on cover label), the override shaft must be pressed down firmly at least 1/4" in order to disengage the motor from the gears. The manual override is not designed to overcome torque in excess of the rated torque of the actuator. Serious damage to the gear system may result from excessive turning force on the manual override.
- This Series actuator may be mounted in any position, i.e. horizontal, upside down. If the conduit entrance points upward, conduit piping must be oriented as to prevent condensation from entering the actuator from the conduit pipe.

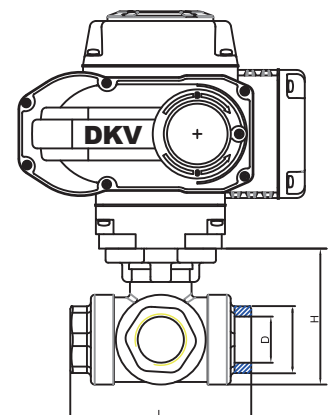

## Introduction

Quick open and close, less flowing resistance. PTFE sealing, perfect sealing, high temperature, corrosion resistance, acid and alkali resistance. The main features of the valve itself is compact, easy operation and maintenance for water, acids and natural gas general working media.

## Electric Actuator

ON/OFF Type	Feedback: the Active Contact Signal, Passive Contact Signal, Resistance, 4-20mA
Regulation Type	Input & Output Signal: DC 4-20mA, DC 0-10V, DC 1-5V
Field Operation	The Field, Remote Control Switch Regulation and MODBUS, PROFIBUS Field Bus
Voltage Optional	AC110-240V 380V 50/60Hz; DC12V, DC24V, Special Voltage Can be Customized
Protection Class	Ip65; Explosion Proof Construction Are Available: EX d II BT4



## Technical Parameters

Valve Body		Valve Components	
Size Range	DN15~DN200	Body Material	Stainless Steel, WCB
Operating Pressure	1.6MPa ~6.4MPa	Core Material	Stainless Steel, WCB
End Connection	Flange	Sealing Material	PTFE: -30°C~180°C PPL: -30°C~250°C
Structure	3 way L-Port/ T-Port	Applicable Media	Control of Water, Air, Gas, Oil, Liquid, Steam

T-Pattern Flow Direction Diagram



## Qutine Size drawing

UNIT: mm

MEDLE	DN15	DN20	DN25	DN32	DN40	DN50	DN65	DN80	DN100	DN125	DN150	DN200
G	1/2"	3/4"	1"	1-1/4"	1-1/2"	2"	2-1/2"	3"	4"	5"	6"	8"
D3	15	20	25	30	40	50	65	80	100	125	150	200
D2	45	55	65	78	85	100	120	135	155	185	210	265
D1	65	75	85	100	110	125	145	160	180	210	240	295
D	95	105	115	135	145	160	180	195	215	245	280	335
L	150	164	180	200	220	240	260	280	320	380	440	550
H	53	58.5	70	77.5	88.5	92	107	119	150	200	240	300
B	72	80	90	100	110	120	130	140	160	190	220	260
n-φd	4-φ14	4-φ14	4-φ14	4-φ18	4-φ18	4-φ18	4-φ18	8-φ18	8-φ18	8-φ18	8-φ28	4-φ23
Weight (Kg)												
Actuator	DKV -05		DKV -10		DKV -16	DKV -30		DKV -60	DKV -125	DKV -250	DKV -400	

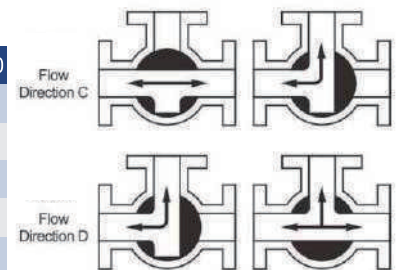

L-Pattern Flow Direction Diagram

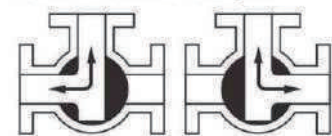

## Installation Instruction

- Before installing the valve, clean the line of dirt, scale, welding chips, and other foreign material. Clean gasket surfaces thoroughly to insure leak-proof joints.
- Verify that the valve breakaway torque is less than the rated output torque of the actuator.
- Any mechanical stops that would interfere with the operation of the actuator must be removed before installation of the actuator, i.e. lever, travel stops, etc.
- The actuator output coupling must be centered with the valve stem to prevent side loading, which causes premature stem packing wear.
- To use the manual override feature (identified on cover label), the override shaft must be pressed down firmly at least 1/4" in order to disengage the motor from the gears. The manual override is not designed to overcome torque in excess of the rated torque of the actuator. Serious damage to the gear system may result from excessive turning force on the manual override.
- This Series actuator may be mounted in any position, i.e. horizontal, upside down. If the conduit entrance points upward, conduit piping must be oriented as to prevent condensation from entering the actuator from the conduit pipe.

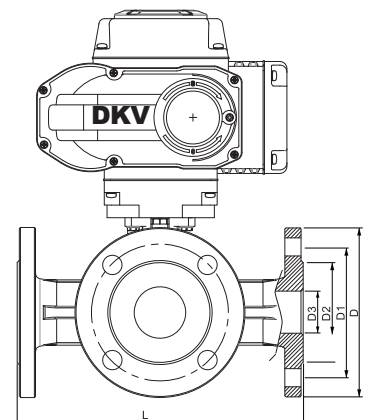

### Introduction

Sanitary pneumatic 3 way ball valves has been through the sophisticated inspection process and strict quality management. Using internal and external polishing and sterilization. Clamp quick connection, all-inclusive seal, easy to disassemble, cleaning and maintenance. Three-way sanitary ball valve for sanitary pipelines medium commutation, diversion, confluence, mixed flow. They can be manually operated or automated with an electric or pneumatic actuator.

### Electric Actuator

ON/OFF Type	Feedback: the Active Contact Signal, Passive Contact Signal, Resistance, 4-20mA
Regulation Type	Input & Output Signal: DC 4-20mA, DC 0-10V, DC 1-5V
Field Operation	The Field, Remote Control Switch Regulation and MODBUS, PROFIBUS Field Bus
Voltage Optional	AC110-240V 380V 50/60Hz; DC12V, DC24V, Special Voltage Can be Customized
Protection Class	Ip65; Explosion Proof Construction Are Available: EX d II BT4

### Technical Parameters

Body		Valve components	
Nominal Size	DN15~DN100	Seat Material	PTFE: -30°C~180°C PPL: -30°C ~ 250°C
Body Material	SS304, SS316, SS316L	Disc Material	SS304, SS316, SS316L
Connection Type	Clamp, Welding	Stem Material	SS304,
Pressure Rating	PN1.6MPa	Design Standard	ISO、DIN、IDF、SMS、3A
Structure type	Floating ball core 3 way L-type/ T-type ball valve	Applicable Medium	Food, Medicine, Packaging Machinery, Filling Machinery And Other Health Conditions Using Level.

### Qutine Size drawing

Size	Ø19	Ø25	Ø32	Ø38	Ø51	Ø63	Ø76	Ø89	Ø102
DN	DN15	DN20	DN25	DN32	DN40	DN50	DN65	DN80	DN100
d	16	22	29	35	48	59	72	85	98
D	50.5	50.5	50.5	50.5	64	77.5	91	106	119
L	105	126	138	155	186	200	220	240	268
H	45	48	52.5	65	74	84	102	112	122
B	60	61.5	69	77	91	109	122	135	150
Actuator	DKV-05			DKV -10			DKV -16		DKV -30
Weight (kg)	3.95	4.1	4.4	4.8	7.4	9.1	11.6	13.6	17.3

### Installation Instruction

- Before installing the valve, clean the line of dirt, scale, welding chips, and other foreign material. Clean gasket surfaces thoroughly to insure leak-proof joints.
- Verify that the valve breakaway torque is less than the rated output torque of the actuator.
- Any mechanical stops that would interfere with the operation of the actuator must be removed before installation of the actuator, i.e. lever, travel stops, etc.
- The actuator output coupling must be centered with the valve stem to prevent side loading, which causes premature stem packing wear.
- To use the manual override feature (identified on cover label), the override shaft must be pressed down firmly at least 1/4" in order to disengage the motor from the gears. The manual override is not designed to overcome torque in excess of the rated torque of the actuator. Serious damage to the gear system may result from excessive turning force on the manual override.
- This Series actuator may be mounted in any position, i.e. horizontal, upside down. If the conduit entrance points upward, conduit piping must be oriented as to prevent condensation from entering the actuator from the conduit pipe.



T-Pattern Flow Direction Diagram

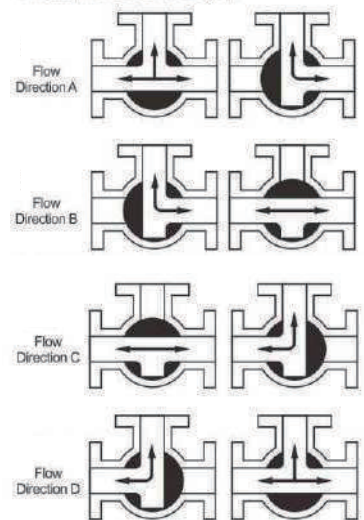

L-Pattern Flow Direction Diagram

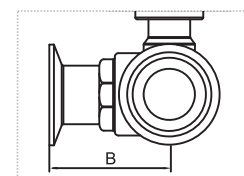
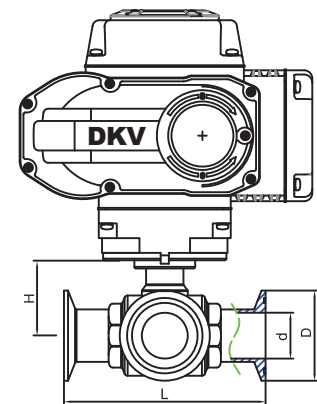
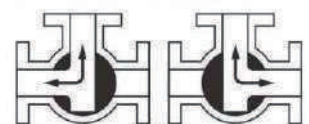

## Introduction

Ultra Low Torque, Elegant, Durable. Corrosion Resistance Full Flow. PTFE Ball sealing. Low Torque Can Use the Handle Regulating Valve Seat Tightness Released By The Central Section Is Still Intact. Valves. Replaceable To Provide Supplementary Platform Embedded Copper Nut Products Convenient Automatic Actuator



## Electric Actuator

ON/OFF Type	Feedback: the Active Contact Signal, Passive Contact Signal, Resistance, 4-20mA
Regulation Type	Input & Output Signal: DC 4-20mA, DC 0-10V, DC 1-5V
Field Operation	The Field, Remote Control Switch Regulation and MODBUS, PROFIBUS Field Bus
Voltage Optional	AC110-240V 380V 50/60HZ; DC12V, DC24V, Special Voltage Can be Customized
Protection Class	Ip65; Explosion Proof Construction Are Aailable: EX d II BT4

## Technical Parameters

Body		Valve components	
Nominal size	DN15~DN50	Seat material	EPDM
Body material	Plastic UPVC	Core material	Plastic UPVC
Connection type	Double union	Stem material	SS304, SS410
Pressure Rating	PN1.0MPa PN1.6MPa	Applicable Medium	Water, Liquids. Gas, Oil. Powder. Steam. Acid-base Corrosive Medium.
Structure type	Floating ball core		

T-Pattern Flow Direction Diagram

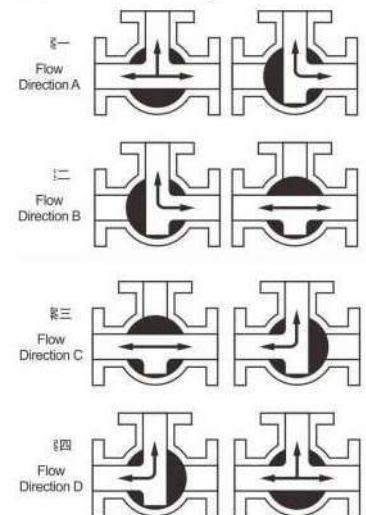

L-Pattern Flow Direction Diagram

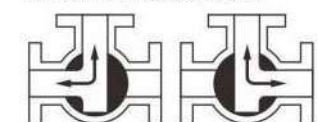

## Qutine Size drawing

MEDLE	DN15	DN20	DN25	DN32	DN40	DN50
G	1/2"	3/4"	1"	1-1/4"	1-1/2"	2"
d	14	20	25	30	38	50
D	20	25	32	40	50	63
D1	30	36	45	55	64	77
L1	22.8	25	28.5	32	34.8	39
L	163	172	200	206	240	246
H	79	79	82	82	110	110
Weight (Kg) Actuator	4.2	4.3	4.9	5.1	7.7	6.1
	DKV-05			DKV-10		

## Installation Instruction

1. Before installing the valve, clean the line of dirt, scale, welding chips, and other foreign material Clean gasket surfaces thoroughly to insure leak-proof joints.
2. Verify that the valve breakaway torque is less than the rated output torque of the actuator.
3. Any mechanical stops that would interfere with the operation of the actuator must be removed before installation of the actuator, i.e. lever, travel stops, etc.
4. The actuator output coupling must be centered with the valve stem to prevent side loading, which causes premature stem packing wear.
5. To use the manual override feature (identified on cover label), the override shaft must be pressed down firmly at least 1/4" in order to disengage the motor from the gears. The manual override is not designed to overcome torque in excess of the rated torque of the actuator. Serious damage to the gear system may result from excessive turning force on the manual override.
6. This Series actuator may be mounted in any position, i.e. horizontal, upside down. If the conduit entrance points upward, conduit piping must be oriented as to prevent condensation from entering the actuator from the conduit pipe.

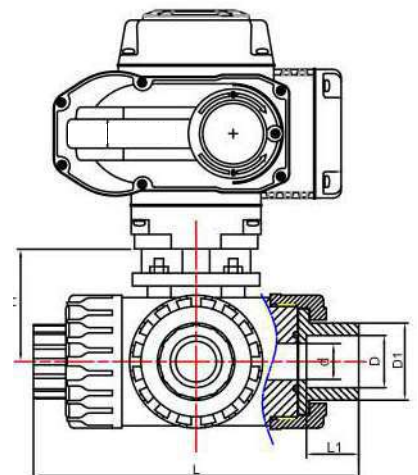

## Introduction

Ultrahigh pressure ball is adopt ball core rotate 90 degrees to open or close the valve, the brick, high pressure forging with German import seal assembly, provided by initial seal, stainless steel butterfly spring cushion packing seal surface enhanced with medium pressure rise, self sealing performance is strong, super high pressure ball valve can be used in the ultra high pressure liquid, ultrahigh pressure gas or the mixture of main application industry has ultrahigh pressure testing machine, pneumatic pumps, hydraulic pump, deep-sea detectors.

## Electric Actuator

ON/OFF Type	Feedback: the Active Contact Signal, Passive Contact Signal, Resistance, 4-20mA
Regulation Type	Input & Output Signal: DC 4-20mA, DC 0-10V, DC 1-5V
Field Operation	The Field, Remote Control Switch Regulation and MODBUS, PROFIBUS Field Bus
Voltage Optional	AC110-240V 380V 50/60Hz; DC12V, DC24V, Special Voltage Can be Customized
Protection Class	Ip65; Explosion Proof Construction Are Aailable: EX d II BT4



## Technical Parameters

Body		Valve components	
Nominal Size	DN15~DN200	Seat Material	PTFE: -30°C ~180°C
Body Material	SS304, SS316, SS316L		PPL: -30°C ~ 250°C
Connection Type	Flange	Disc Material	SS304, SS316, SS316L
Pressure Rating	PN1.6~PN6.3MPa	Stem Material	SS304,
Structure type	Floating ball core	Applicable Medium	Water, Liquids, Gas, Oil, Powder, Steam, Acid-base Corrosive Medium.

## Qutine Size drawing

UNIT: mm

MEDLE	DN08	DN10	DN15	DN20	DN25	DN32	DN40	DN50
G	1/4"	3/8"	1/2"	3/4"	1"	1-1/4"	1-1/2"	2"
D	8	10	15	20	25	32	40	50
B	64	64	65	80	95	107	123	
H	43	43	43	53	64	70	79	
L	80	80	82	101	120	127	150	
L1	19	19	20	25	29	30	28	
L2	19	19	20	25	29	30	28	

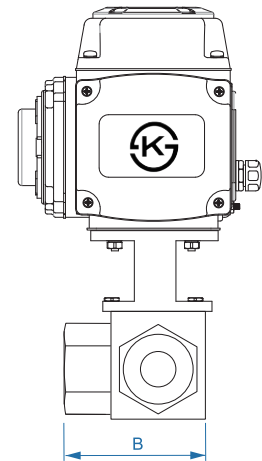

## Installation Instruction

1. Verify that the valve breakaway torque is less than the rated output torque of the actuator.
2. Any mechanical stops that would interfere with the operation of the actuator must be removed before installation of the actuator, i.e. lever, travel stops, etc.
3. The actuator output coupling must be centered with the valve stem to prevent side loading, which causes premature stem packing wear.
4. To use the manual override feature (identified on cover label), the override shaft must be pressed down firmly at least 1/4" in order to disengage the motor from the gears. The manual override is not designed to overcome torque in excess of the rated torque of the actuator. Serious damage to the gear system may result from excessive turning force on the manual override.
5. This Series actuator may be mounted in any position, i.e. horizontal, upside down. If the conduit entrance points upward, conduit piping must be oriented as to prevent condensation from entering the actuator from the conduit pipe.

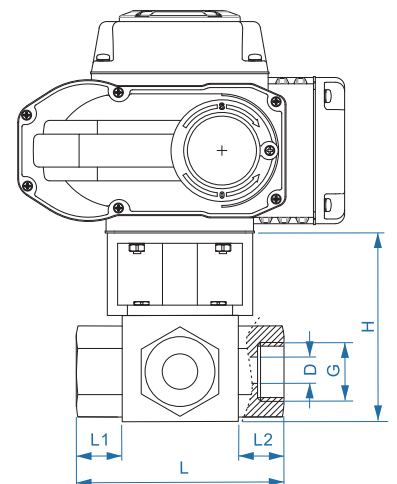

## Introduction

According to the sealing performance, pneumatic butterfly valve can be divided into metal seal and soft seal type. Advantages pneumatic butterfly valve over other type valves may include: compact structure, miniature size, long service life, good sealing performance, easy maintenance, quick detachable and installation.

## Electric Actuator

ON/OFF Type	Feedback: the Active Contact Signal, Passive Contact Signal, Resistance, 4-20mA
Regulation Type	Input & Output Signal: DC 4-20mA, DC 0-10V, DC 1-5V
Field Operation	The Field, Remote Control Switch Regulation and MODBUS, PROFIBUS Field Bus
Voltage Optional	AC110-240V 380V 50/60Hz; DC12V, DC24V, Special Voltage Can be Customized
Protection Class	Ip65; Explosion Proof Construction Are Aailable: EX d II BT4

## Technical Parameters

Body		Valve components	
Size Range	DN50-DN600	Seating Material	NBR, EPDM, VITON, PTFE
Body material	SS, CI, Ductile Iron, WCB	Disc Material	SS, CI, Ductile Iron, WCB
End Connection	Wafer Flange	Stem Material	Stainless Steel
Operating Pressure	< 1.6MPa	Applicable media	Control of Water, Air, Gas, Oil, Liquid, Steam
Structure	Midline Structure / A-type		

## Qutine Size drawing

UNIT: mm

MEDLE	DN50	DN65	DN80	DN100	DN125	DN150	DN200	DN250	DN300	DN350	DN400	DN500
Inch	2"	2-1/2"	3"	4"	5"	6"	8"	10"	12"	14"	16"	20"
D	50	65	80	100	125	150	200	250	300	350	400	500
D1	96	104	127	153	180	206	270	320	368	428	482	605
D2	125	145	160	180	210	240	295	355	410	470	525	585
L	45	47	48	58	59	59	64	70	78	80	108	120
H	212	225	256	280	315	345	405	480	554			
n-φd	4-φ18	4-φ18	4-φ18	4-φ18	4-φ18	4-φ23	4-φ23	4-φ23	4-φ26	4-φ26	4-φ26	4-φ30
Weight (Kg)	5.2	5.6	6.2	8.9	10.3	11.7	18.8	24.8	43.34			
Actuator	DKV-05	DKV-05	DKV-05	DKV-10	DKV-10	DKV-16	DKV-30	DKV-30	DKV-60	DKV-60	DKV-125	DKV-250

## Installation Instruction

1. When removing the valve from storage, a careful check should be made to ensure that the valve has not been damaged during the storage period.
2. Valve open or close position is indicated on the notch plate for lever operated valves or on the top of the gear operator for gear operator operated valves.
3. Center valve, span body with bolts, but do not tighten. Slowly open disc to ensure that it clears adjacent pipe ID and leave at full open position.
4. For flange welding center valve with disc 10 open between flanges, span bolts, align this assembly in pipe and tack weld flanges to pipe. After tack welding, remove valve and finish welding.
5. Valve should be checked for identification purpose and ensure that characteristics of valve matches to those specified for piping specifications, for the line where that is to be mounted. Nameplate instructions will give the necessary information.

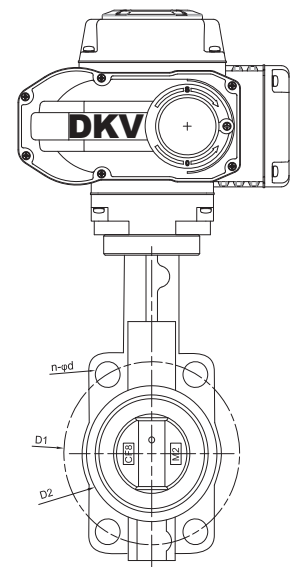
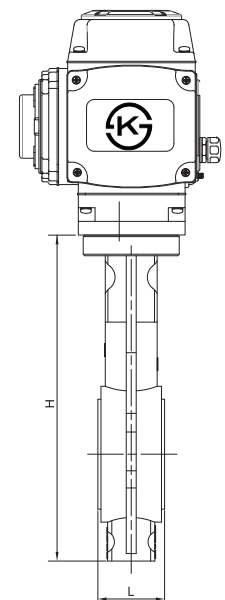

## Introduction

According to the sealing performance, pneumatic butterfly valve can be divided into metal seal and soft seal type. Advantages pneumatic butterfly valve over other type valves may include: compact structure, miniature size, long service life, good sealing performance, easy maintenance, quick detachable and installation.

## Electric Actuator

ON/OFF Type	Feedback: the Active Contact Signal, Passive Contact Signal, Resistance, 4-20mA
Regulation Type	Input & Output Signal: DC 4-20mA, DC 0-10V, DC 1-5V
Field Operation	The Field, Remote Control Switch Regulation and MODBUS, PROFIBUS Field Bus
Voltage Optional	AC110-240V 380V 50/60Hz; DC12V, DC24V, Special Voltage Can be Customized
Protection Class	Ip65; Explosion Proof Construction Are Aailable: EX d II BT4



## Technical Parameters

Body		Valve components	
Size Range	DN50-DN600	Seating Material	NBR, EPDM, VITON, PTFE
Body material	Stainless Steel	Disc Material	Stainless Steel
End Connection	Wafer Flange	Stem Material	Stainless Steel
Operating Pressure	< 1.6MPa	Applicable media	Control of Water, Air, Gas, Oil, Liquid, Steam
Structure	Midline Structure / A-type		

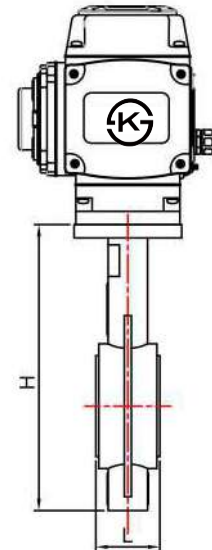

## Qutine Size drawing

UNIT: mm

MEDLE	DN50	DN65	DN80	DN100	DN125	DN150	DN200	DN250	DN300	DN350	DN400	DN500
Inch	2"	2-1/2"	3"	4"	5"	6"	8"	10"	12"	14"	16"	20"
D	52.7	64.4	78.8	104.2	123.3	157	202.5	250.5	301.6	333.3	389.6	491.6
D1	89	104	127	153	180	206	270	320	368	428	482	605
D2	125	145	160	180	210	240	295	355	410	470	525	585
L	41	43	45	50	54	54	60	66	75.5	86.5	86.5	131.8
H	207	219	232	262	265	296	353	390	460	508	597	677
n-φd	4-φ18	4-φ18	4-φ18	4-φ18	4-φ18	4-φ23	4-φ23	4-φ23	4-φ26	4-φ26	4-φ26	4-φ30
Weight (Kg)	5.2	5.6	7.2	8.9	10.3	11.7	18.8	24.8	30.5			
Actuator	DKV-05	DKV-05	DKV-05	DKV-10	DKV-10	DKV-16	DKV-30	DKV-30	DKV-60	DKV-60	DKV-125	DKV-250

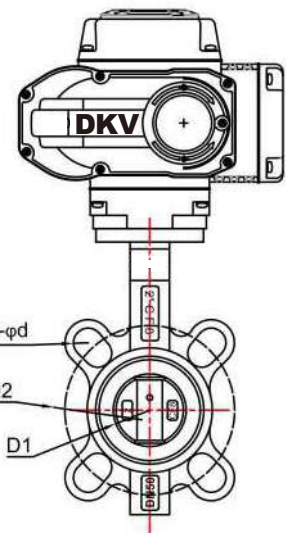

## Installation Instruction

1. When removing the valve from storage, a careful check should be made to ensure that the valve has not been damaged during the storage period.
2. Valve open or close position is indicated on the notch plate for lever operated valves or on the top of the gear operator for gear operator operated valves.
3. Center valve, span body with bolts, but do not tighten. Slowly open disc to ensure that it clears adjacent pipe ID and leave at full open position.
4. For flange welding center valve with disc 10 open between flanges, span bolts, align this assembly in pipe and tack weld flanges to pipe. After tack welding, remove valve and finish welding.
5. Valve should be checked for identification purpose and ensure that characteristics of valve matches to those specified for piping specifications, for the line where that is to be mounted. Nameplate instructions will give the necessary information.

## Introduction

According to the sealing performance, pneumatic butterfly valve can be divided into metal seal and soft seal type. Advantages pneumatic butterfly valve over other type valves may include: compact structure, miniature size, long service life, good sealing performance, easy maintenance, quick detachable and installation.

## Electric Actuator

ON/OFF Type	Feedback: the Active Contact Signal, Passive Contact Signal, Resistance, 4-20mA
Regulation Type	Input & Output Signal: DC 4-20mA, DC 0-10V, DC 1-5V
Field Operation	The Field, Remote Control Switch Regulation and MODBUS, PROFIBUS Field Bus
Voltage Optional	AC110-240V 380V 50/60Hz; DC12V, DC24V, Special Voltage Can be Customized
Protection Class	Ip65; Explosion Proof Construction Are Available: EX d II BT4



## Technical Parameters

Body		Valve components	
Size Range	DN50-DN600	Seating Material	NBR, EPDM, VITON, PTFE
Body material	Stainless Steel	Disc Material	Stainless Steel
End Connection	Wafer Flange	Stem Material	Stainless Steel
Operating Pressure	< 1.6MPa	Applicable media	Control of Water, Air, Gas, Oil, Liquid, Steam
Structure	Midline Structure / A-type		

## Qutine Size drawing

UNIT: mm

MEDLE	DN50	DN65	DN80	DN100	DN125	DN150	DN200	DN250	DN300	DN350	DN400	DN500
Inch	2"	2-1/2"	3"	4"	5"	6"	8"	10"	12"	14"	16"	20"
D	52.7	64.4	78.8	104.2	123.3	157	202.5	250.5	301.6	333.3	389.6	491.6
D1	89	104	127	153	180	206	270	320	368	428	482	605
D2	125	145	160	180	210	240	295	355	410	470	525	585
L	41.4	44	45	52	54	54	55	60	65	76	86	130
H	217	234	252	289	318	341	428	490	567			
n-φd	4-M16	4-M16	8-M16	8-M16	8-M16	8-M20	12-M20	12-M24	12-M24			
Actuator	DKV-05	DKV-05	DKV-05	DKV-10	DKV-10	DKV-16	DKV-30	DKV-30	DKV-60			

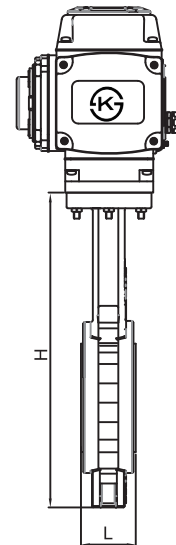

## Installation Instruction

- When removing the valve from storage, a careful check should be made to ensure that the valve has not been damaged during the storage period.
- Valve open or close position is indicated on the notch plate for lever operated valves or on the top of the gear operator for gear operator operated valves.
- Center valve, span body with bolts, but do not tighten. Slowly open disc to ensure that it clears adjacent pipe ID and leave at full open position.
- For flange welding center valve with disc 10 open between flanges, span bolts, align this assembly in pipe and tack weld flanges to pipe. After tack welding, remove valve and finish welding.
- Valve should be checked for identification purpose and ensure that characteristics of valve matches to those specified for piping specifications, for the line where that is to be mounted. Nameplate instructions will give the necessary information.

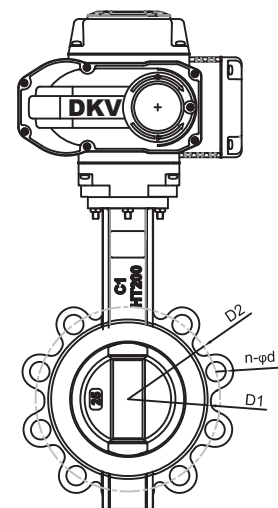

## Introduction

According to the sealing performance, pneumatic butterfly valve can be divided into metal seal and soft seal type. Advantages pneumatic butterfly valve over other type valves may include: compact structure, miniature size, long service life, good sealing performance, easy maintenance, quick detachable and installation.



## Electric Actuator

ON/OFF Type	Feedback: the Active Contact Signal, Passive Contact Signal, Resistance, 4-20mA
Regulation Type	Input & Output Signal: DC 4-20mA, DC 0-10V, DC 1-5V
Field Operation	The Field, Remote Control Switch Regulation and MODBUS, PROFIBUS Field Bus
Voltage Optional	AC110-240V 380V 50/60Hz; DC12V, DC24V, Special Voltage Can be Customized
Protection Class	Ip65; Explosion Proof Construction Are Aailable: EX d II BT4

## Technical Parameters

Body		Valve components	
Size Range	1.1/2"-32"	Seating Material	NBR, EPDM, VITON, PTFE
Body material	SS, CI, Ductile Iron, WCB	Disc Material	Stainless Steel . WCB
End Connection	150LB	Stem Material	Stainless Steel . WCB
Operating Pressure	< 1.6MPa	Applicable media	Control of Water, Air, Gas, Oil, Liquid, Steam
Structure	Midline Structure / A-type		

## Qutine Size drawing

UNIT: mm

MEDLE	DN50	DN65	DN80	DN100	DN125	DN150	DN200	DN250	DN300	DN350	DN400	DN500
Inch	2"	2-1/2"	3"	4"	5"	6"	8"	10"	12"	14"	16"	20"
D1	152	178	190	229	255	279	343	406	483	533	597	698
D2	120.7	139.7	152.4	190.5	215.9	241.3	298.5	362	432	476	540	635
D3	92.1	104.8	127	157.2	185.7	215.9	269.9	323.8	381	412.8		
L	110	112	114	127	140	140	150	165	185	195	216	229
H	192	207	224	255	290	325	386	460	510	565	632	759
n-φd	4-φ19	4-φ19	4-φ19	4-φ23	4-φ23	4-φ23	4-φ23	12-φ25	12-φ25	16-φ29	16-φ29	20-φ32

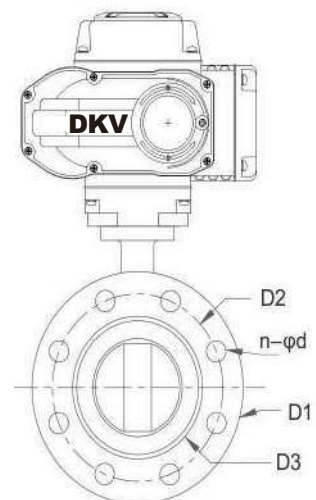
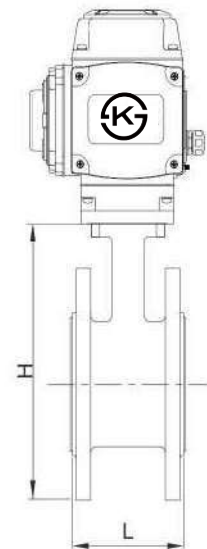

## Installation Instruction

1. When removing the valve from storage, a careful check should be made to ensure that the valve has not been damaged during the storage period.
2. Valve open or close position is indicated on the notch plate for lever operated valves or on the top of the gear operator for gear operator operated valves.
3. Center valve, span body with bolts, but do not tighten. Slowly open disc to ensure that it clears adjacent pipe ID and leave at full open position.
4. For flange welding center valve with disc 10 open between flanges, span bolts, align this assembly in pipe and tack weld flanges to pipe. After tack welding, remove valve and finish welding.
5. Valve should be checked for identification purpose and ensure that characteristics of valve matches to those specified for piping specifications, for the line where that is to be mounted. Nameplate instructions will give the necessary information.

## Introduction

According to the sealing performance, pneumatic butterfly valve can be divided into metal seal and soft seal type. Advantages pneumatic butterfly valve over other type valves may include: compact structure, miniature size, long service life, good sealing performance, easy maintenance, quick detachable and installation.

## Electric Actuator

ON/OFF Type	Feedback: the Active Contact Signal, Passive Contact Signal, Resistance, 4-20mA
Regulation Type	Input & Output Signal: DC 4-20mA, DC 0-10V, DC 1-5V
Field Operation	The Field, Remote Control Switch Regulation and MODBUS, PROFIBUS Field Bus
Voltage Optional	AC110-240V 380V 50/60Hz; DC12V, DC24V, Special Voltage Can be Customized
Protection Class	Ip65; Explosion Proof Construction Are Aailable: EX d II BT4



## Technical Parameters

Body		Valve components	
Size Range	DN50-DN800	Seating Material	NBR, EPDM, VITON, PTFE
Body material	SS, CI, Ductile Iron, WCB	Disc Material	Stainless Steel, WCB
End Connection	Flange	Stem Material	Stainless Steel, WCB
Operating Pressure	< 1.6MPa	Applicable media	Control of Water, Air, Gas, Oil, Liquid, Steam
Structure	Midline Structure / A-type		

## Qutine Size drawing

UNIT: mm

MEDLE	DN50	DN65	DNB0	DN100	DN125	DN150	DN200	DN250	DN300	DN350	DN400	DN500
Inch	2"	2-1/2"	3"	4"	5"	6"	8"	10"	12"	14"	16"	20"
D	52.7	64.4	83	104.2	123.3	157	202.5	250.5	301.6	333.3	389.6	491.6
D1	165	185	200	220	250	285	340	395	445	505	565	670
D2	125	145	160	180	210	240	295	355	410	470	525	620
D3	99	118	132	156	184	211	266	319	370	429	480	582
L	108	112	114	127	140	140	150	165	185	195	216	229
H	192	207	224	255	290	325	386	460	510	565	632	759
n-φd	4-φ18	4-φ18	8-φ18	8-φ18	8-φ18	8-φ22	8-φ22	12-φ22	12-φ22	16-φ22	16-φ26	20-φ22

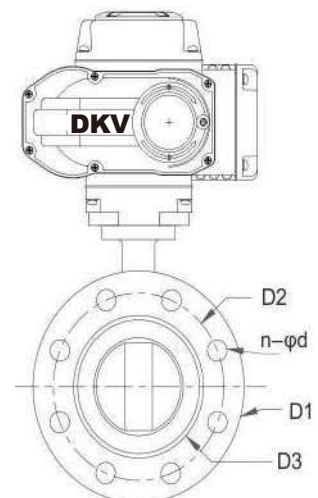
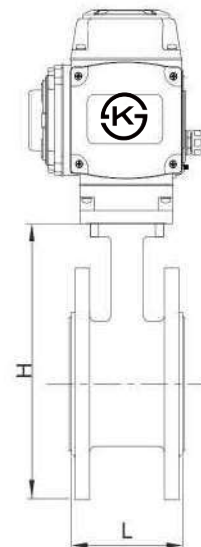

## Installation Instruction

1. When removing the valve from storage, a careful check should be made to ensure that the valve has not been damaged during the storage period.
2. Valve open or close position is indicated on the notch plate for lever operated valves or on the top of the gear operator for gear operator operated valves.
3. Center valve, span body with bolts, but do not tighten. Slowly open disc to ensure that it clears adjacent pipe ID and leave at full open position.
4. For flange welding center valve with disc 10 open between flanges, span bolts, align this assembly in pipe and tack weld flanges to pipe. After tack welding, remove valve and finish welding.
5. Valve should be checked for identification purpose and ensure that characteristics of valve matches to those specified for piping specifications, for the line where that is to be mounted. Nameplate instructions will give the necessary information.

## Introduction

Fluorine lined butterfly valve is in the conventional butterfly valve and valve plate lined with teflon, so that the media and valve body isolation, antiseptic effect. The valve has more and more close closure function, sealing performance is reliable. Applicable to any concentration of acid, alkali, salt and oxidative extrusion, reducing agent, organic solvents and other media.

## Electric Actuator

ON/OFF Type	Feedback: the Active Contact Signal, Passive Contact Signal, Resistance, 4-20mA
Regulation Type	Input & Output Signal: DC 4-20mA, DC 0-10V, DC 1-5V
Field Operation	The Field, Remote Control Switch Regulation and MODBUS, PROFIBUS Field Bus
Voltage Optional	AC110-240V 380V 50/60Hz; DC12V, DC24V, Special Voltage Can be Customized
Protection Class	Ip65; Explosion Proof Construction Are Available: EX d II BT4



## Technical Parameters

Body		Valve components	
Size Range	DN50-DN600	Seating Material	PTFE
Body material	Stainless Steel	Disc Material	Stainless Steel
End Connection	Wafer Flange	Stem Material	Stainless Steel
Operating Pressure	<1.6MPa	Applicable media	Control of Water, Air, Gas, Oil, Liquid, Steam
Structure	Midline Structure / A-type		

UNIT: mm

## Qutine Size drawing

MEDLE	DN50	DN65	DN80	DN100	DN125	DN150	DN200	DN250	DN300	DN350	DN400	DN500
Inch	2"	2-1/2"	3"	4"	5"	6"	8"	10"	12"	14"	16"	20"
D	50	65	80	100	125	150	200	250	300	350	400	500
D1	96	104	127	153	180	206	270	320	368	428	482	605
D2	125	145	160	180	210	240	295	355	410	470	525	585
L	43	46	46	52	56	56	60	68	78	78	102	127
L1	108	112	114	127	140	140	152	165	178	190	216	229
H	212	230	233	270	298	337	407	480	555	610	715	870
n-φd	4-φ18	4-φ18	8-φ18	8-φ18	8-φ18	8-φ23	8-φ23	12-φ23	12-φ23	16-φ23	16-φ25	20-φ25
Actuator	DKV-05	DKV-05	DKV-05	DKV-10	DKV-10	DKV-16	DKV-30	DKV-30	DKV-60			

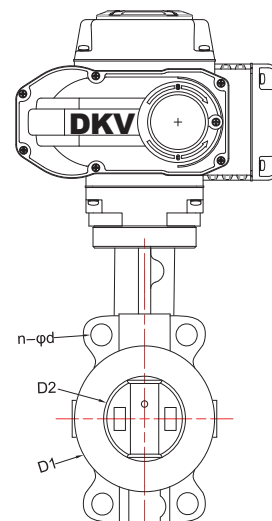
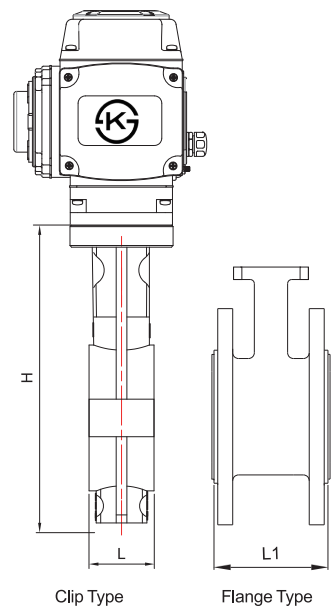

## Installation Instruction

- When removing the valve from storage, a careful check should be made to ensure that the valve has not been damaged during the storage period.
- Valve open or close position is indicated on the notch plate for lever operated valves or on the top of the gear operator for gear operator operated valves.
- Center valve, span body with bolts, but do not tighten. Slowly open disc to ensure that it clears adjacent pipe ID and leave at full open position.
- For flange welding center valve with disc 10 open between flanges, span bolts, align this assembly in pipe and tack weld flanges to pipe. After tack welding, remove valve and finish welding.
- Valve should be checked for identification purpose and ensure that characteristics of valve matches to those specified for piping specifications, for the line where that is to be mounted. Nameplate instructions will give the necessary information.

## Introduction

PVC plastic butterfly valve according to the different medium has a variety of optional material, corrosive resistance is strong, adapt to large diameter, small volume, light weight, health non-toxic material, easy maintenance and replacement.

## Electric Actuator

ON/OFF Type	Feedback: the Active Contact Signal, Passive Contact Signal, Resistance, 4-20mA
Regulation Type	Input & Output Signal: DC 4-20mA, DC 0-10V, DC 1-5V
Field Operation	The Field, Remote Control Switch Regulation and MODBUS, PROFIBUS Field Bus
Voltage Optional	AC110-240V 380V 50/60Hz; DC12V, DC24V, Special Voltage Can be Customized
Protection Class	Ip65; Explosion Proof Construction Are Aailable: EX d II BT4



## Technical Parameters

Valve Body		Valve Components	
Size Range	DN50-DN600	Body Material	UPVC, CPVC, RPP, PVDF
Operating Pressure	1.0MPa	Stem Material	UPVC, CPVC, RPP, PVDF
End Connection	Wafer, Flange	Sealing Material	EPDM, NBR
Structure	Midline Structure A Type	Applicable Media	Compatible PVC Food Industry Chemical Solvents

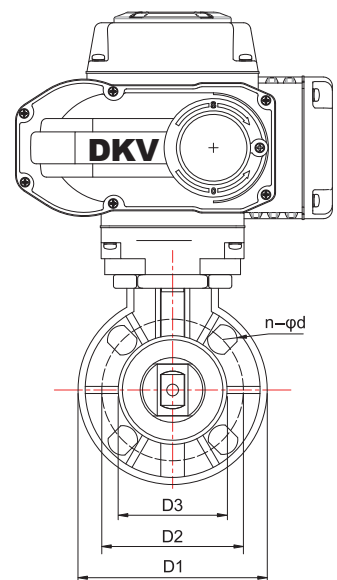
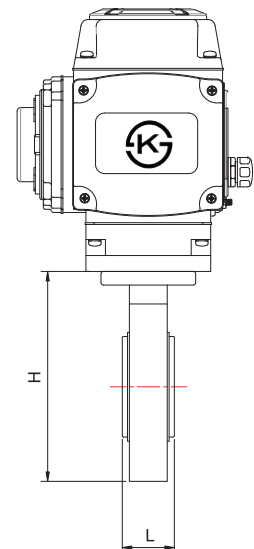

## Qutine Size drawing

UNIT: mm

MEDLE	DN50	DN65	DN80	DN100	DN125	DN150	DN200	DN250	DN300	DN350	DN400	DN500
Inch	2"	2-1/2"	3"	4"	5"	6"	8"	10"	12"	14"	16"	20"
D	52.7	64.4	83	104.2	123.3	157	202.5	250.5	301.6	333.3	389.6	491.6
D1	165	185	200	220	250	285	340	395	445	505	565	670
D2	125	145	160	180	210	240	295	355	410	470	525	620
D3	99	118	132	156	184	211	266	319	370	429	480	582
L	108	112	114	127	140	140	150	165	185	195	216	229
H	192	207	224	255	290	325	386	460	510	565	632	759
n-φd	4-φ18	4-φ18	8-φ18	8-φ18	8-φ18	8-φ22	8-φ22	12-φ22	12-φ22	16-φ22	16-φ26	20-φ26
Weight (Kg)	4.48	4.48	5.28	7.38	7.78	9.02	10.48					

## Installation Instruction

1. When removing the valve from storage, a careful check should be made to ensure that the valve has not been damaged during the storage period.
2. Valve open or close position is indicated on the notch plate for lever operated valves or on the top of the gear operator for gear operator operated valves.
3. Center valve, span body with bolts, but do not tighten. Slowly open disc to ensure that it clears adjacent pipe ID and leave at full open position.
4. For flange welding center valve with disc 10 open between flanges, span bolts, align this assembly in pipe and tack weld flanges to pipe. After tack welding, remove valve and finish welding.
5. Valve should be checked for identification purpose and ensure that characteristics of valve matches to those specified for piping specifications, for the line where that is to be mounted. Nameplate instructions will give the necessary information.

## Introduction

The 3 piece design allows for the center part of the valve containing the ball, stem & seats to be easily removed from the pipeline. This facilitates efficient cleaning of deposited sediments, replacement of seats and gland packings, polishing out of small scratches on the ball, all this without removing the pipes from the valve body. The design concept of a three piece valve is for it to be repairable.

## Electric Actuator

ON/OFF Type	Feedback: the Active Contact Signal, Passive Contact Signal, Resistance, 4-20mA
Regulation Type	Input & Output Signal: DC 4-20mA, DC 0-10V, DC 1-5V
Field Operation	The Field, Remote Control Switch Regulation and MODBUS, PROFIBUS Field Bus
Voltage Optional	AC110-240V 380V 50/60Hz; DC12V, DC24V, Special Voltage Can be Customized
Protection Class	Ip65; Explosion Proof Construction Are Aailable: EX d II BT4



## Technical Parameters

Body		Valve components	
Nominal Size	DN15~DN100	Seat Material	PTFE: -30°C~180°C PPL: -30°C ~ 250°C
Body Material	SS304, SS316, SS316L	Disc Material	SS304, SS316, SS316L
Connection Type	Clamp, Welding	Stem Material	SS304,
Pressure Rating	PN1.6MPa	Design Standard	ISO、DIN、IDF、SMS、3A
Structure type	Midline Structure	Applicable Medium	Food, Medicine, Packaging Machinery, Filling Machinery And Other Health Conditions Using Level.

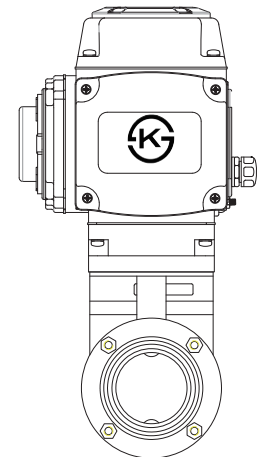

## Qutine Size drawing

UNIT: mm

Size	Ø19	Ø25	Ø32	Ø38	Ø51	Ø63	Ø76	Ø89	Ø102
DN	DN15	DN20	DN25	DN32	DN40	DN50	DN65	DN80	DN100
d	16	21	29	35	47	59	72	85	97
D	50.5	50.5	50.5	50.5	64	77.5	91	106	119
L	68	68	68	72	72	72	81	82.5	85
H	99	99	99	114	125	140	150	165	180
Weight (Kg)	2.78	2.78	2.78	3.28	4.28	5.08	6.18	9.08	10.5
Actuator	DKV-05				DKV-10		DKV-16		DKV-30

## Installation Instruction

1. Verify that the valve breakaway torque is less than the rated output torque of the actuator.
2. Any mechanical stops that would interfere with the operation of the actuator must be removed before installation of the actuator, i.e. lever, travel stops, etc.
3. The actuator output coupling must be centered with the valve stem to prevent side loading, which causes premature stem packing wear.
4. To use the manual override feature (identified on cover label), the override shaft must be pressed down firmly at least 1/4" in order to disengage the motor from the gears. The manual override is not designed to overcome torque in excess of the rated torque of the actuator. Serious damage to the gear system may result from excessive turning force on the manual override.
5. This Series actuator may be mounted in any position, i.e. horizontal, upside down. If the conduit entrance points upward, conduit piping must be oriented as to prevent condensation from entering the actuator from the conduit pipe.

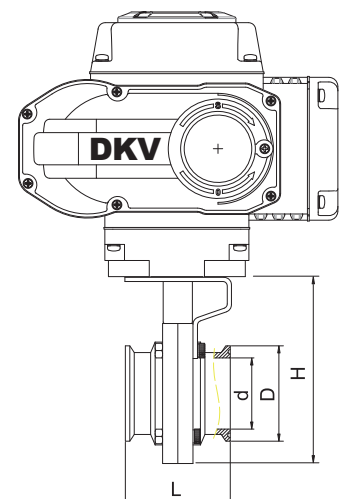

---

---

## Main Functions and Key Features

1. Body: body material is hard aluminum alloy, which is treated by hard anodic oxidation and coated by Polyester powder, so that it has great corrosion resistance and protection class IP67.
2. Motor: fully enclosed cage type motor is small in size and inertia, large in torque. Insulation class is F grade which can prevent motor over-heating;
3. Manual Override: small handle is reliable, energy-saving. It can be used for manual operation when electricity is off; In automatic operation, it can be fixed inside the clip for easy operation;
4. Indicator: indicator is assembled on center axis, valve position can be observed; Outside mirror design facilitates position observation and prevents water drops accumulation;
5. Enclosure: high sealing performance, standard protection class is IP67;
6. Limit Switches: mechanical and electronic position limit switches. Mechanical stop screw can be adjustable; Electronic limit switches can be controlled by cam. Position can be set easily and accurately by simply adjusting the cam without any influence by handle;
7. Self Lock: accurate turbo-worm structure can output large torque with high efficiency and little noise (Max. 50 decibel). Service life is quite long. Its self lock function can stop reverse rotation. Drive part is stable and reliable without additional lubrication;
8. Captive Bolt: bolts won't fall off when cover is disassembled;
9. Application: bottom connection complies with ISO5211/DIN3337 Standard. Star square hole is easy for square valve stem linear or 45° rotation application; Both vertical and horizontal assemble are available;
10. Diagram: control diagram complies with single phase or three phase wiring standard, reasonable wiring diagram and connection terminal can meet requirement of other optional functions.



Manual Override



ON/OFF Type



Regulation Type



Intelligent Type

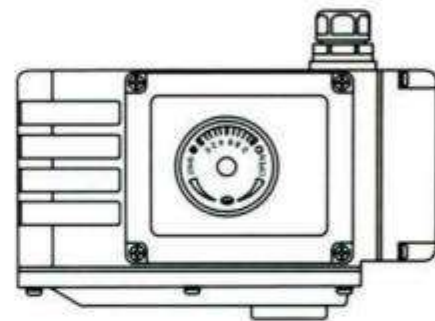
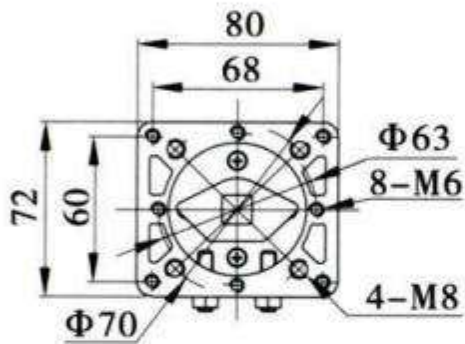
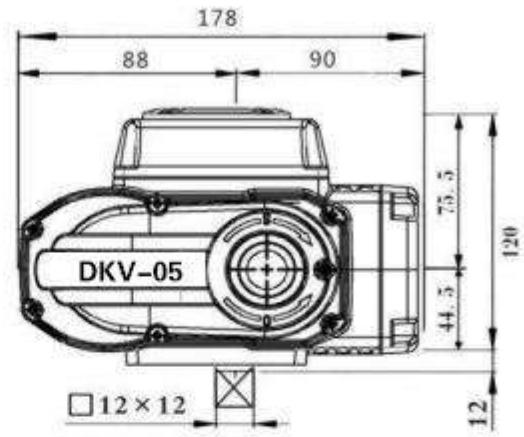
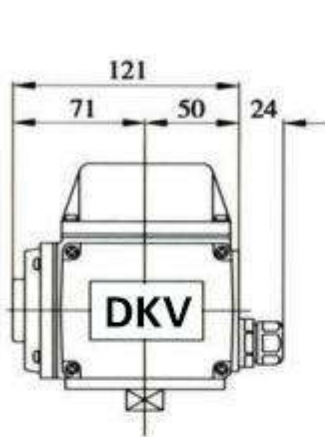

**DKV-10/16**

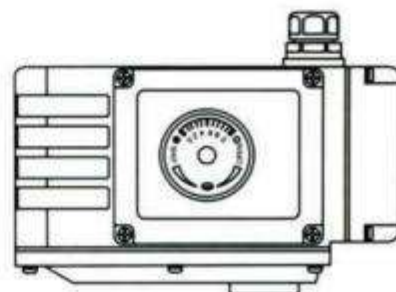
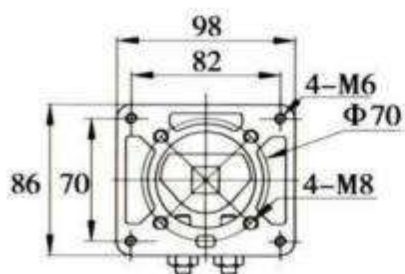
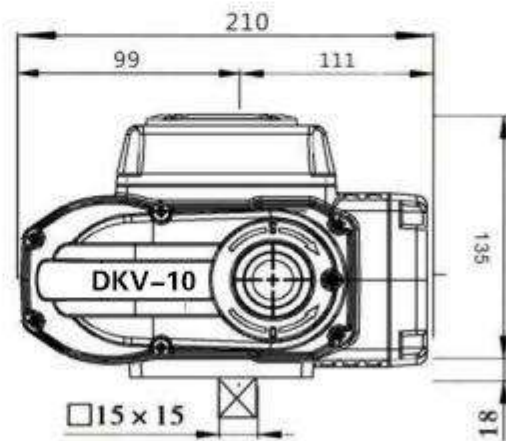
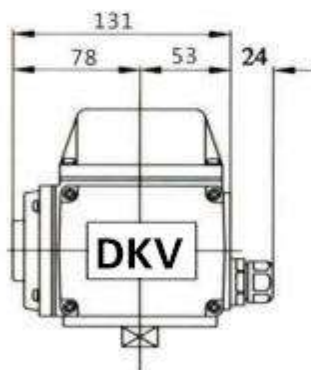

**DKV-30/60**

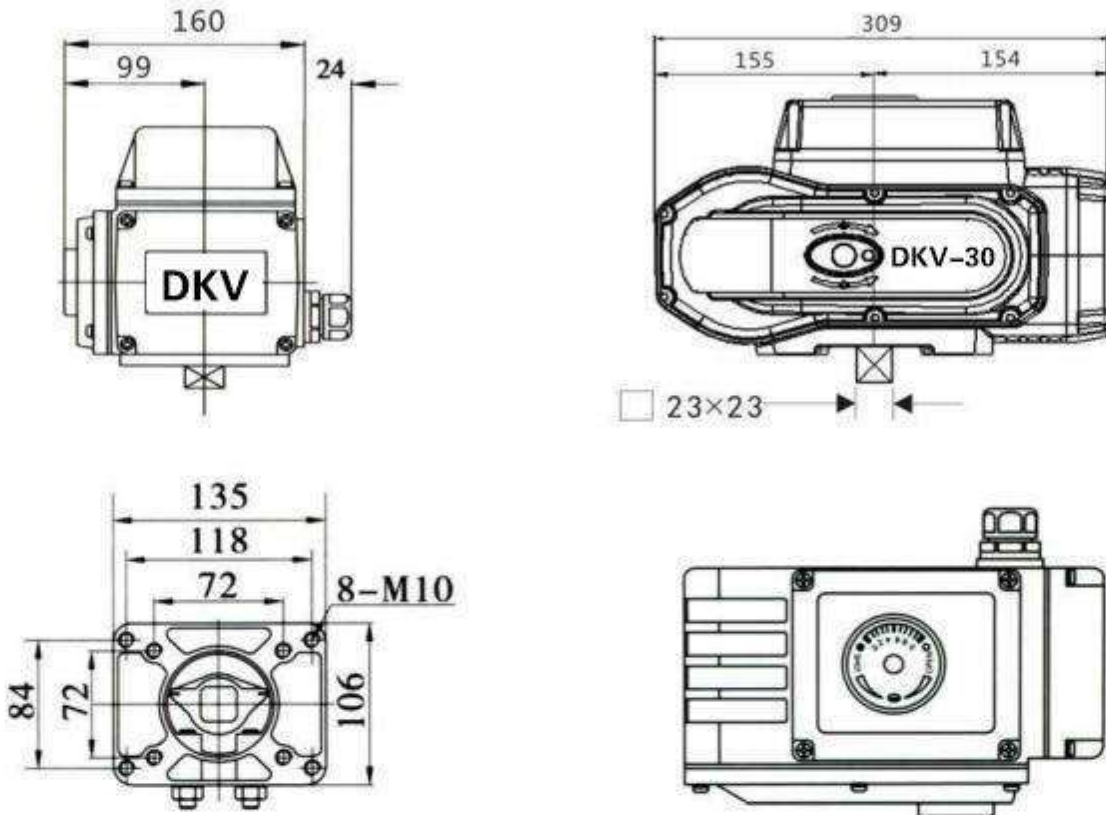

**COVNA-125/250/400**

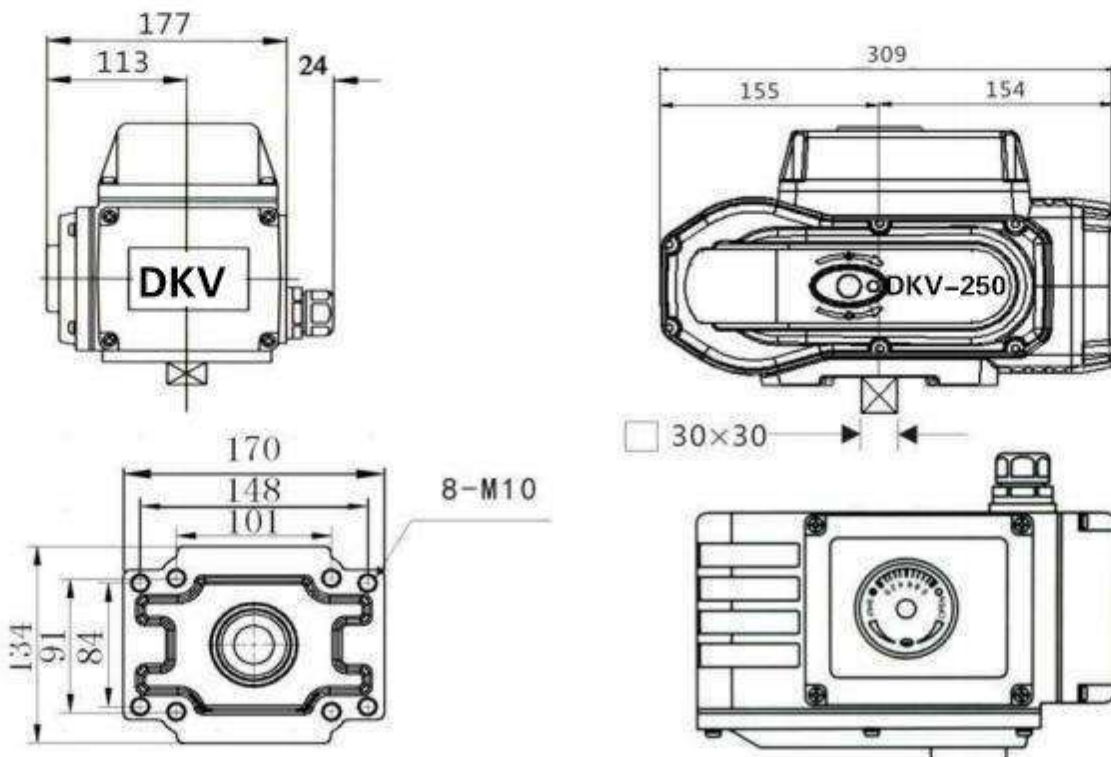

### ON/OFF Type

Performance Model	05	10	16	30	60	125	250	400
Torque Output	50Nm	100Nm	160Nm	300Nm	600Nm	1250Nm	2500Nm	4000Nm
90° Cycle Time	20S/60S	15S/30S/60S			30S/60S	90S	90S	90S
Angle of Rotation	0-90°	0-90°	0-90°	0-90°	0-90°	0-90°	0-90°	0-90°
Working Current	0.23A	0.35A	0.40A	0.45A	0.60A	1.03A	1.85A	2.7A
AC220V Drive Motor	50W	75W	80W	100W	130W	210W	285W	360W
Product Weight	3KG	5KG	5.5KG	8KG	8.5KG	15KG	15.5KG	16KG
Voltage Options	AC110V, AC220V, AC380V, DC24V, AC24V							
Insulation Resistance	DC24V; 100MΩ/250V; AC110/220V/380V; 100MΩ/500V							
Withstand Voltage	DC24V; 500V; AC110/220V; 1500V; AC380V; 1800V 1Minute							
Protection Class	IP65							
Installation Angle	Any							
Electrical Connection	G1/2 Water-proof Cable Connectors, Electric Power Wire, Signal Wire							
Ambient Temp.	-30°C to +60°C							
Control Circuit	A: ON/OFF Type with Light Indicator Signal Feedback B: ON/OFF Type with Passive Contact Signal Feedback C: ON/OFF Type with Resistance Potentiometer Signal Feedback D: ON/OFF Type with Resistance Potentiometer and Neutral Position Signal Feedback E: Regulation Type with Servo Control Module F: DC24V/ DC12V Direct ON/OFF Type G: AC380V Three-Phase Power Supply with Passive Signal Feedback H: AC380V Three-Phase Power Supply with Resistance Potentiometer Signal							
Optional Function	Over Torque Protectors, Dehumidify Heater, Stainless Steel Coupling & Yoke							

Note: 1. The power and current of the above actuators are measured by standard AC220V, which will be biased due to voltage instability in actual use. Other AC DC voltage power and current are converted by 10% according to this table.  
 2. Output Torque: torque deviation of 10%

### Regulation Type

Performance / Model	05	10	16	30	60	125	250	400
Torque Output	50Nm	100Nm	160Nm	300Nm	600Nm	1250Nm	2500Nm	4000Nm
90° Cycle Time	20S	15S/30S	15S/30S	15S/30S	30S	100S	100S	100S
Angle of Rotation	0-90°	0-90°	0-90°	0-90°	0-90°	0-90°	0-90°	0-90°
Working Current	0.23A	0.35A	0.40A	0.45A	0.60A	1.03A	1.85A	2.7A
Drive Motor	50W	75W	80W	100W	130W	210W	285W	360W
Product Weight	3KG	5KG	5.5KG	8KG	8.5KG	15KG	15.5KG	16KG
Voltage Options	AC110V, AC220V, AC380V, DC24V, AC24V							
Input Signal	4-20mADC 1-5VDC 0-10VDC							
Output Signal	4-20mADC 1-5VDC 0-10VDC							
Tolerance	±0.5%							
Return Difference	<0.3%							
Dead Zone	0.1% to 1.6%							
Damping Characteristics	0							
Mechanical Repeatability Error	0%							

**Note:**

90° Cycle Time: travel from closed position to open position or vice versa  
 Duty Cycle for 24VAC will be approximately 20%

Note: 1. The power and current of the above actuators are measured by standard AC220V, which will be biased due to voltage instability in actual use. Other AC/DC voltage power and current are converted by 10% according to this table.  
 2. Output Torque: torque deviation of 10%

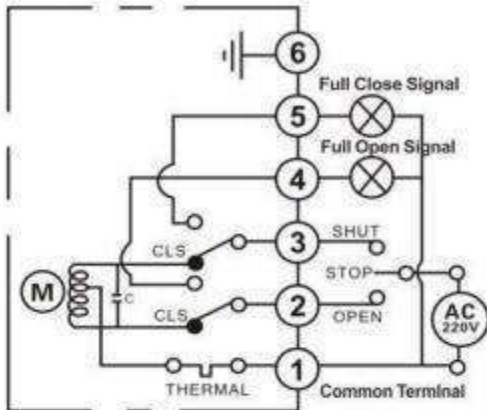

**A: ON/OFF Type with Light Indicator Signal Feedback**

**Function:** Finish open or close operations by the circuit, and the actuator outputs a signal of active position (full opening, full closing)

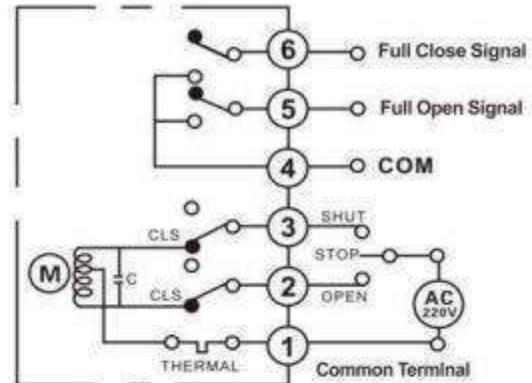

**B: ON/OFF Type with Passive Contact Signal Feedback**

**Function:** Finish open or close operations by the circuit, and the actuator outputs a set signal of passive position (full opening, full closing)

**Structure:** with two neutral positions switches

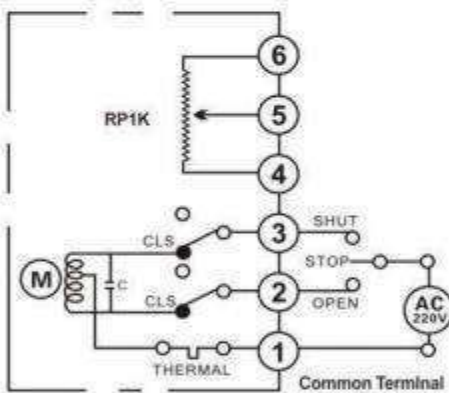

**C: ON/OFF Type with Resistance Potentiometer Signal Feedback**

**Function:** Control the open angle of valves by circuit, and the actuator outputs the resistance signal corresponding to the position of switch

**Structure:** with 500Ω or 1000Ω potentiometer

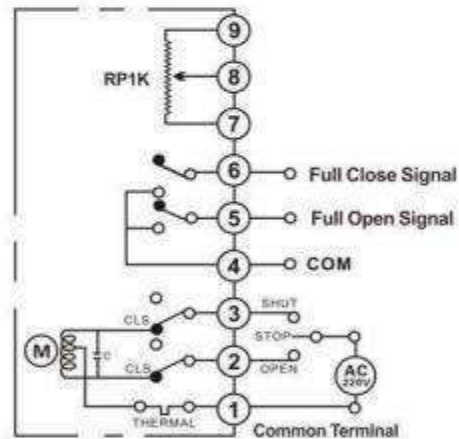

**D: ON/OFF Type with Resistance Potentiometer and Neutral Position Signal Feedback**

**Function:** control the open angle of valves by circuit, and the actuator outputs the resistance signal corresponding to the position of open position, at the same time, outputting a set signal of passive position

**Structure:** both potentiometer style and neutral positions switch style

**Caution:**

Can't connect one actuator parallel with other ones, in other words, can't use the same controller contact points to control two and above actuators, otherwise it will cost out of control, motor overheating, product damage and shorter service life.

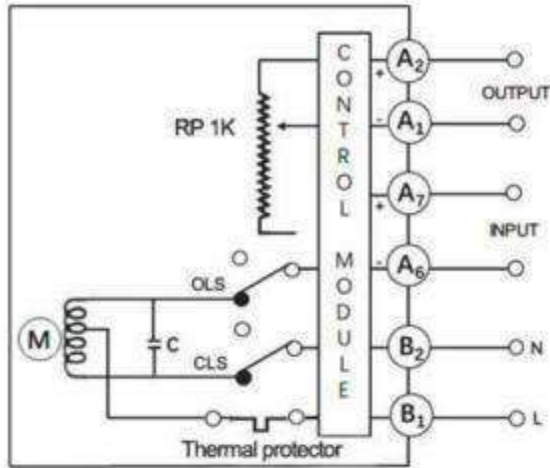

**E: Regulation Type with Servo Control Module**

**Function:** Modulating, input & output

DC4-20mA, 1-5VDC, 0-10VDC

**Structure:** With servo control module and 1000  $\Omega$  potentiometer

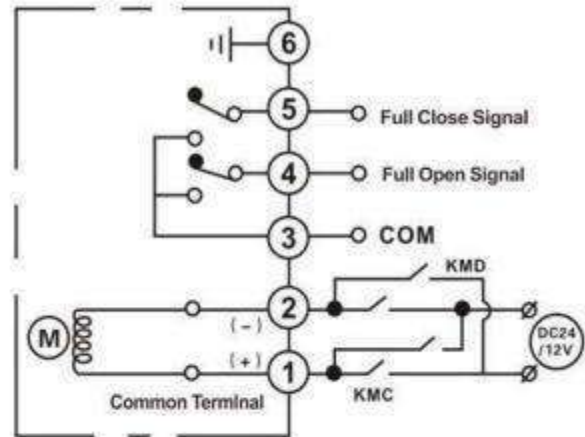

**F: DC24V/DC12V Direct ON-OFF Type**

**Function:** The external circuit make positive and negative conversion of DC power to open or close, and the actuator outputs a set signal of passive position (full opening, full closing)

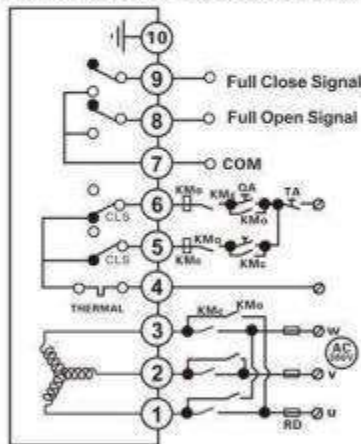

**G: AC380V Three-Phase Power Supply with Passive Signal Feedback**

**Function:** The external circuit make positive and negative conversion of DC power to open or close, and the actuator outputs a set signal of passive position (full opening, full closing)

**Notes:**

Please kindly note if the switch position is correct when the three phase electric actuator is being adjusted, if it's opposite direction, then make 2 of power lines exchange each other

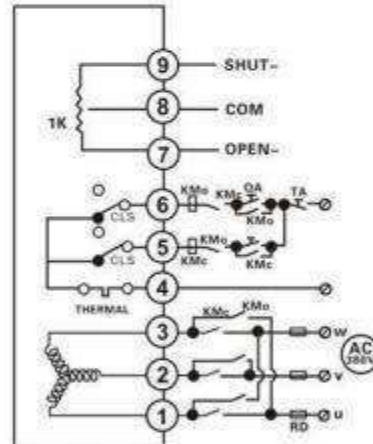

**H: AC380V Three-Phase Power Supply with Resistance Potentiometer Signal Feedback**

**Function:** The external circuit make positive and negative conversion of DC power to open or close, and the actuator outputs a set signal of passive position (full opening, full closing)

**Notes:**

Please kindly note if the switch position is correct when the three phase electric actuator is being adjusted, if it's opposite direction, then make 2 of power lines exchange each other

**Caution:**

Can't connect one actuator parallel with other ones, in other words, can't use the same controller contact points to control two and above actuators, otherwise it will cost out of control, motor overheating, product damage and shorter service life.

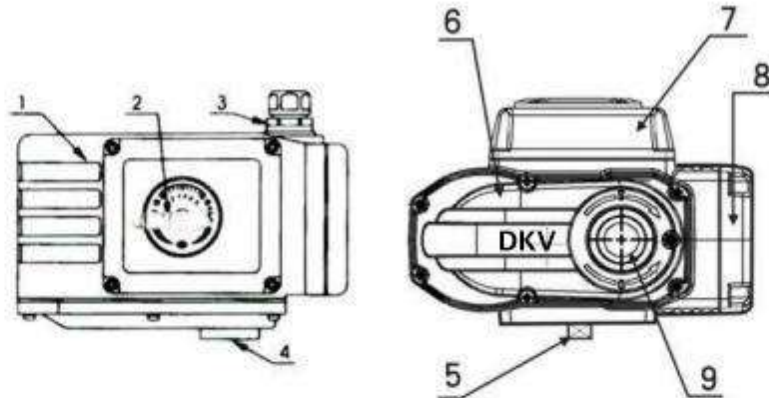

Construction					
1	Shell	4	Rubber Cap	7	Electric Cover
2	Position Indicator	5	Output Shaft	8	Terminal Box
3	Inlet Wire Lock	6	Gear Box Cover	9	Manual Override

The actuator are fully debugged before they go out, if they don't meet your demands because of the valve body, the coupling in actual installation. Please resume debugging according to following steps:

- **Assembly the actuator to the valve (refer to Installation)**
- **Discharge the electric cover of actuator and debug as following steps according to the actual state of valve:**

- ① Adjustment of limit position switch (refer to Commissioning):
- ② Adjustment of neural position switch (refer to Commissioning);
- ③ Adjustment of regulation type actuator (only for E style, refer to Commissioning of regulation type actuator),
- ④ Adjustment of mechanical limited location block (refer to Commissioning).

• **The manual test run**

- ① Take off the rubber cap of manual handle hole; inset the hand shank into hole and rotate it clockwise decreased valve opening.
- ② Check whether the limit switch is running or not when the valve is full closing position (sensitive switch making crack sound when it is running), then turn the adjusting screw a half turn to check if the screw could touch the mechanical limited location block.
- ③ Turn hand shank anticlockwise to increase valve opening, check the situation of limit switch and mechanical limit location block the same method, make trial tum to see whether they are all right.

• **The electric test run**

- ① Take off terminal box, wiring correctly according to wiring diagram
- ② Separately tum on the power on clockwise and anticlockwise and see whether the actuator and the valve are working correctly.) The direction of shut point (clockwise) show close, the direction of open point (anticlockwise) show open.

## 1. Installation environment

- The product can be installed indoor and outdoor.
- product is non-explosion-proof production, and the installation must be avoided being in flammable or explosive environment etc.
- The actuator should be in protection box in the environment of long-term with the splash of rain, material and direct sunlight.
- Please reserve space for controller, manual operation.

★ The surrounding environment temperature should be in  $-30^{\circ}\text{C}\sim+60^{\circ}\text{C}$

## 2. Temperature of working medium

- When matching with the valve, the actuator body's temperature will a bit rise if medium temperature happen heat transfer.
- If the temperature of medium is high, the bracket has the function of reducing heat conduction.
- Please select the standard bracket if temperature of working medium below  $60^{\circ}\text{C}$ .
- Please select the standard bracket when temperature of working medium above  $60^{\circ}\text{C}$ .

## 3. Installed on the valve body (Figure 3)

- Manually operate the actuator to drive the valve, confirm it does not have abnormal situation. Turn the valve in full closed position.
- Assemble the bracket to the valve body.
- Set one end of couplings on valve spindle.
- Turn the electric actuator to full closing position, and insert output-input shaft into the square holes of couplings.
- Set the screw between the electric actuator and bracket.
- Turn actuator by hand shank, confirm that it moves translation, no eccentric, no skew and no overrun.

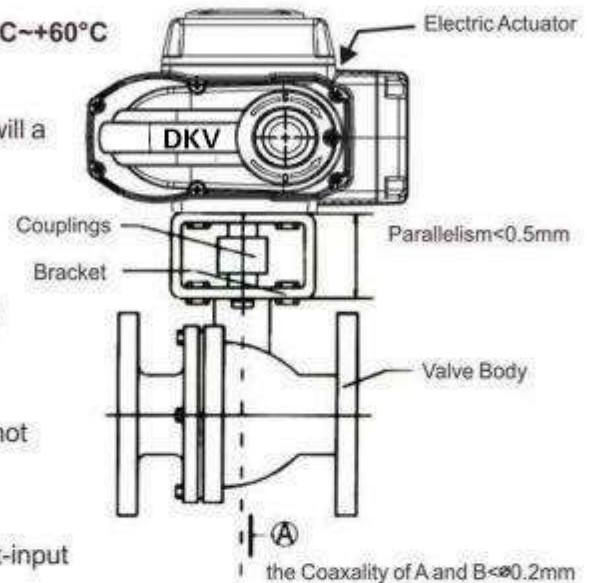

Figure 3

## 4. Cable installation

- Install wire tubes as shown in Figure 4.
- The outside diameter of wire tubes should be  $\varnothing 9\text{--}\varnothing 11$ .
- Take measures to proof water.
- To prevent actuator from flowing into wire tubes water, the actuation position should higher than wire tubes position.
- When installing wire, the outside diameter of wire should be  $\varnothing 9\text{--}\varnothing 11$ .
- As figure 5, in case the water flow into actuator interior from line locking, all wire that are not allowed to be used.
- The signal wire should be shielded wire in principle, don't parallel it to power wire.

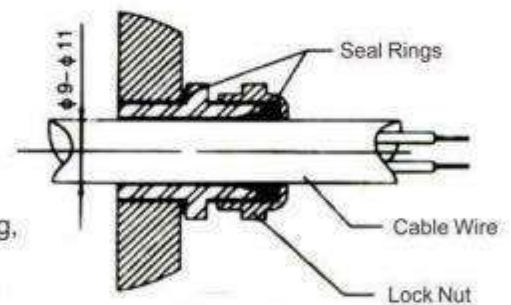

Figure 4

## 5. Special tips

- Caution: can't connect one actuator parallel with one another, in other words, can't use the same controller contact point to control more than one actuator, otherwise it will cause out of control, motor overheating, product damage, shorter service life.
- If the actuator is installed outdoor, we suggest equipping other protective cover to proof water, stabilize mechanical property, make a longer service life.

## 6. Power voltage: 220VAC 50Hz/60Hz

## 7. Guard line options for witch of cutting-off winding

Item	Guard Line	Motor Power W/F
05	3A	10
10/16	5A	25, 30
30/60	7A	40, 90
125/250/400	10A	100, 120, 140

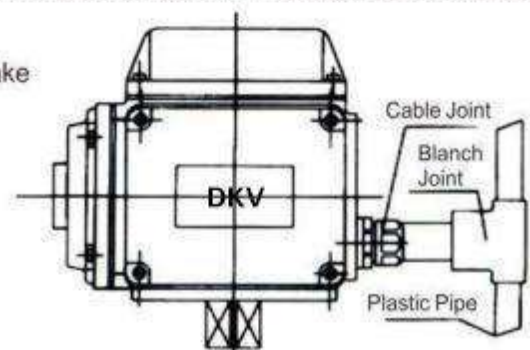
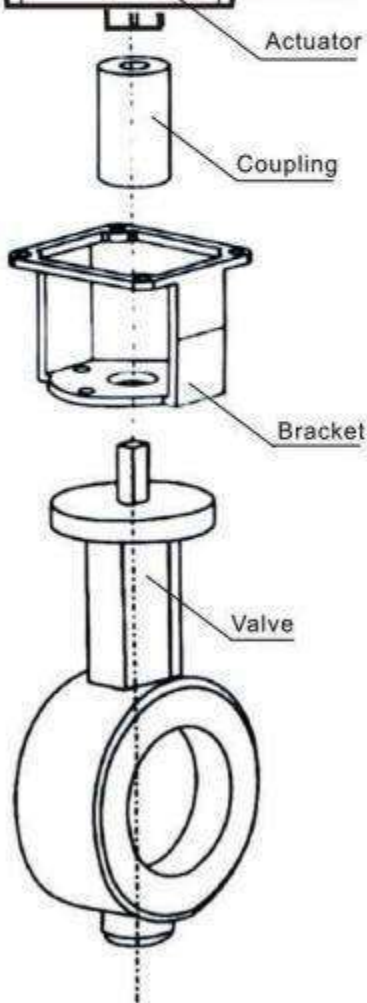
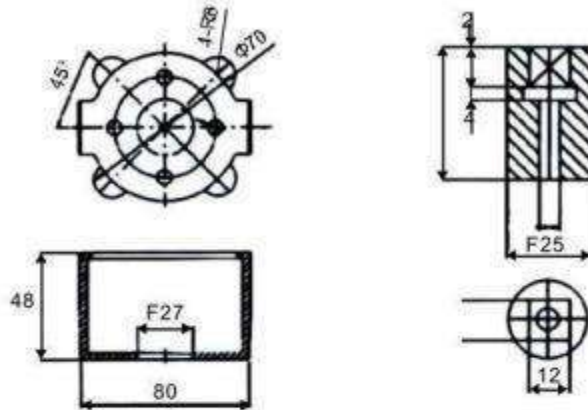

Figure 5

● Z type bracket and couplings (match with 05)



Assembly Drawing



● S type bracket and couplings (match with 10/16)

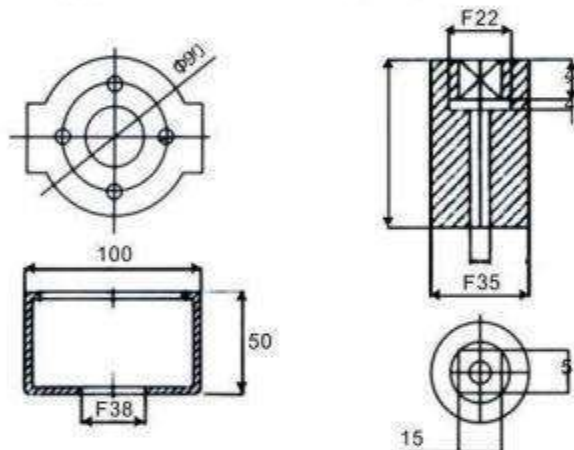

● M type bracket and couplings (match with 10/16)

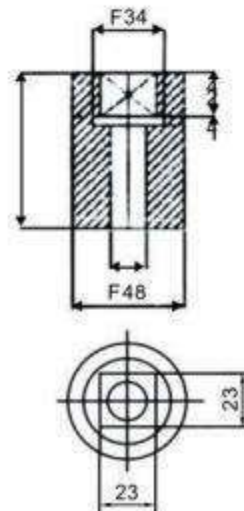
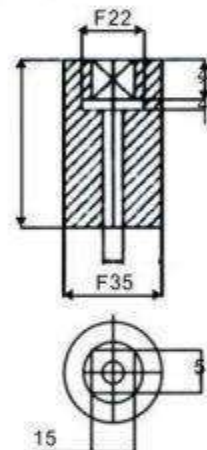
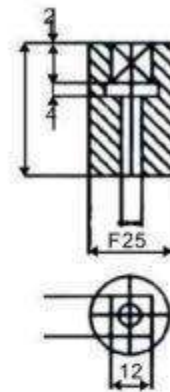
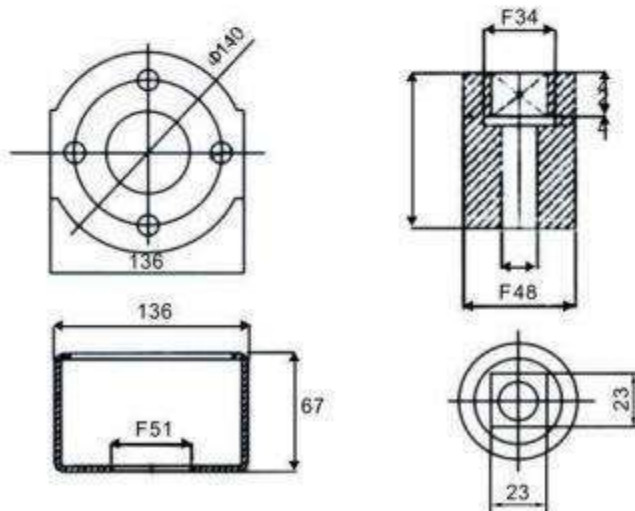

**1. Adjustment of limit position switch (Figure 6)**

- Turn the valve to full opening position by hand.
- Loosen the screw of travel block and turn the block to drive the travel switch, then fine-tuning sensitive switch until hearing "click", after that, set screw.
- The way of adjustment full opening position is the same as above.

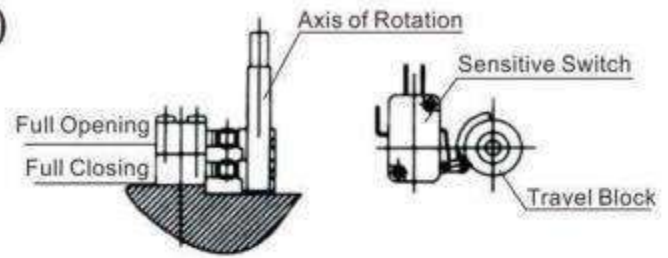

(Figure 6)

**2. Adjustment of middle position switch (Figure 7)**

- Use hand shank to drive the valve to the position it need.
- Loosen the screw of travel block and turn the travel block to drive sensitive switch, then set screw.
- These two neutral position switches' position could be adjusted according to need.

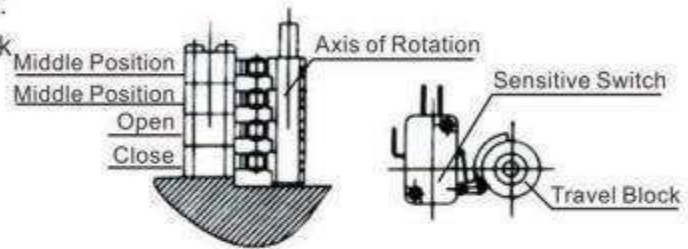

(Figure 7)

**3. Adjustment of potentiometer (Figure 8)**

- Use hand shank to drive actuator to neutral position, and turn the pointer point to 50% scale line.
- Use multimeter to test resistance of first and third port of potentiometer (resistance between the first port and third port in potentiometer), and mark R (potentiometer default is  $1K\Omega \pm 15\%$  if no special request).
- Separate potentiometer gear from the opening gear by suitable external force on potentiometer fixing plate.
- Put one probe of multimeter to one potentiometer terminal, the other probe to another terminal, then rotate potentiometer gear and see number in multimeter. When the resistance value is equivalent to  $R/2 \pm 2\Omega$ , stop rotating, after that, mesh these two gears.

**4. Adjustment of mechanical limit location block (Figure 9)**

- Use hand shank to drive valve to full opening position and operate the switch (sensitive switch makes crack sound when it is running).
- Loosen the nut and turn the adjusting screw to touch the mechanical limit location block, then turn the adjusting screw a half turn back, set nut.
- Adjusting the full opening position by the same way as above.

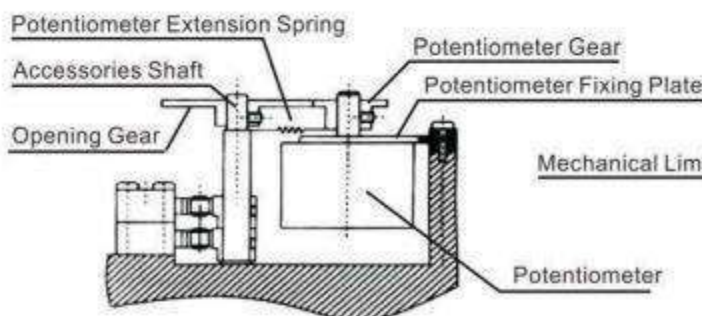

(Figure 8)

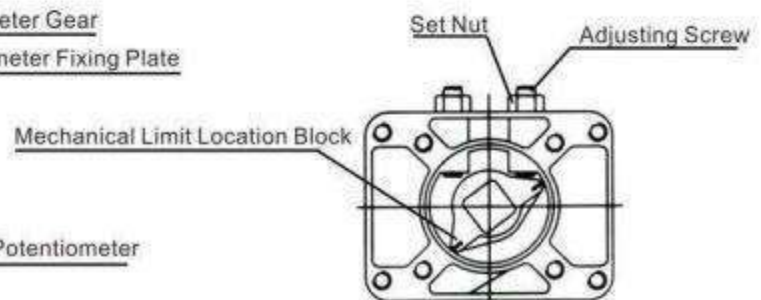

(Figure 9)

## 1. Function of electrical limit and mechanical limit

① Electrical stroke limit function:

When the actuator reaches at fully opened/fully closed or the middle position, the built-in electrical limit switch will cut off the circuit to protect the actuator.

② Mechanical limit function of output shaft:

When electrical stroke limit function fails, output shaft Will be locked by mechanical limit to protect the valve from damage.

Figure 10 shows the position relationship between electrical limit and mechanical limit.

## 2. Adjustment of actuator (Figure 10)

- ① Adjust the over-travel limit stopper to zero position and full position, and ensure electrical limit position angle is 90°.
- ② Adjust mechanical position limitation base on electrical limit position angle.

## 3. Connection of actuator with servo control module

### • Potentiometer installation and connection (Figure 11)

- ① Finish potentiometer installation and connection according to "**Commission**" in previous chapter.
- ② Use multimeter to check resistance of potentiometer in middle opening position, and ensure it has homogeneous continuous variable from 0-100% opening.

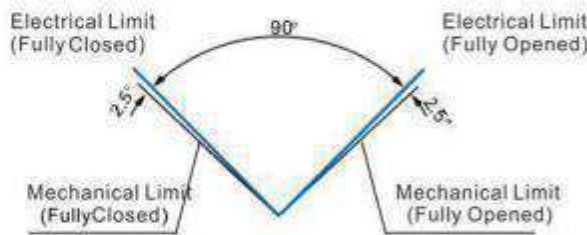

(Figure 10)

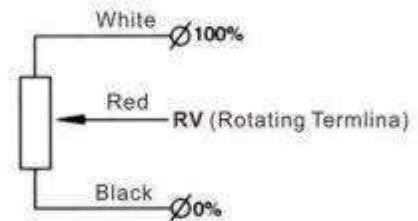

(Figure 11)

### • Electrical wiring of the servo control module (Figure 12)

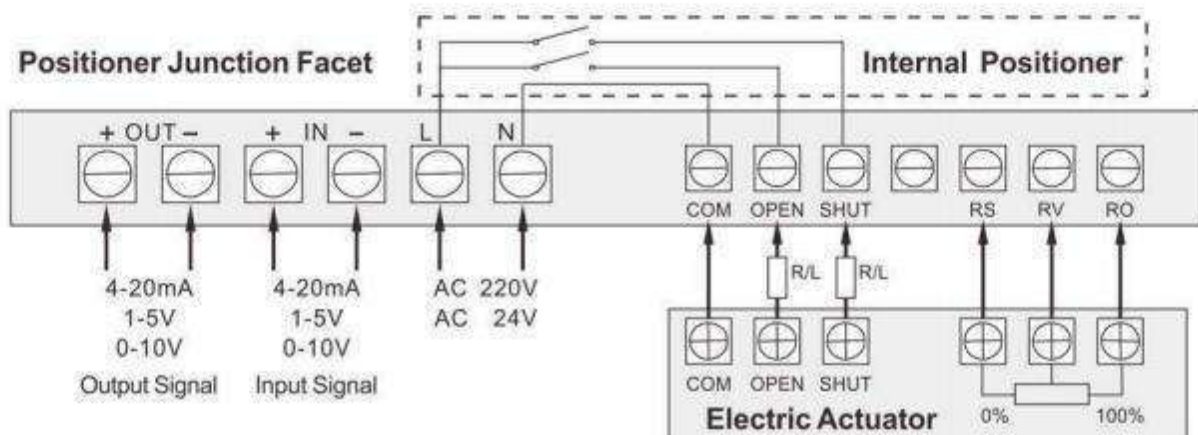

(Figure 12)

## Module Operating Interface



Status indication	1	OPEN	Output control "open"
	2	SHUT	Output control "shut"
	3	MANU	Manual control status
	4	AUTO	Auto control status
Mode indication	5	DRTA	Operating by clockwise, the input signal is corresponding to 4mA-full position (usually we calibrate it to be full opening), 20mA-zero position (usually we set it to be full closing)
	6	RVSA	Operating by anticlockwise, the input signal is corresponding to 4mA-full position (usually we set it to be full opening), 20mA-zero position (usually we calibrate it to be full closing)
	7	OPEN	Input opening signal to make the actuator open to maximum opening degree
	8	STOP	Input stopping signal to make the actuator stop running
	9	SHUT	Input shutting signal to make the actuator shut to minimum closing degree
Button	10	A/M	Automatic or manual mode toggle key, parameter change and toggle key
	11	▲	Values increase button, it use for switching display to original set degree of opening, when it's in automatic mode, opening action when it's maual mode
	12	▼	Values decrease button, it's use for switching display to the temperature of valve positioner shell when it's in automatic mode

## 4. Zero Calibration

After wiring between valve positioner and actuator like Figure 12, the rotation angle has to be calibrated in the first match between positioner and actuator, after that the positioner could work correctly, the demarcation has no effect on input and output of valve positioner.

Method one: simple automatic calibration (this method request the actuator has electric limit position stopper and mechanical limit position stopper). In the automatic mode, press both A/M and buttons at the same time, then release these two buttons at the same time, the actuator will start automatic calibration and confirm the zero position (full closing) first. The valve runs to the small angle direction and reaches at minimal opening position which is judged as zero position (valve position 0.0). After that the actuator runs to maximum opening direction and reaches at maximum opening position which is judged as full position (valve position 100.0). After judgment, the actuator returns to automatic calibration and saves results by itself.

Method two: calibrate your need (this method request button idle time less than 8 seconds in the progress of calibration). In the automatic mode, press A/M button into u0 parameter, pass u1, u2, u3, u4 and into u5, revise u5=003.1, finally press A/M button.

- ① Enter u6, press ▲ or ▼ button to make actuator to run to "open" or "shut" direction, meanwhile, the screen shows the situation of actual valve opening degree is increasing or decreasing. If the opening arrival at Zero position that it's your expected position (you can see it if actuator is already assembled valve body, and the valve is set in full closing position in general), press A/M button to confirm it, enter u7 parameter.
- ② In u7 parameter, press ▲ or ▼ to run to your expected full position in the same way, and press A/M to confirm full position (you can see it If actuator is already assembled valve body, and the valve is set in full opening position in general), then back to u5.
- ③ Revise u-00.5 and back to measurement and control status.

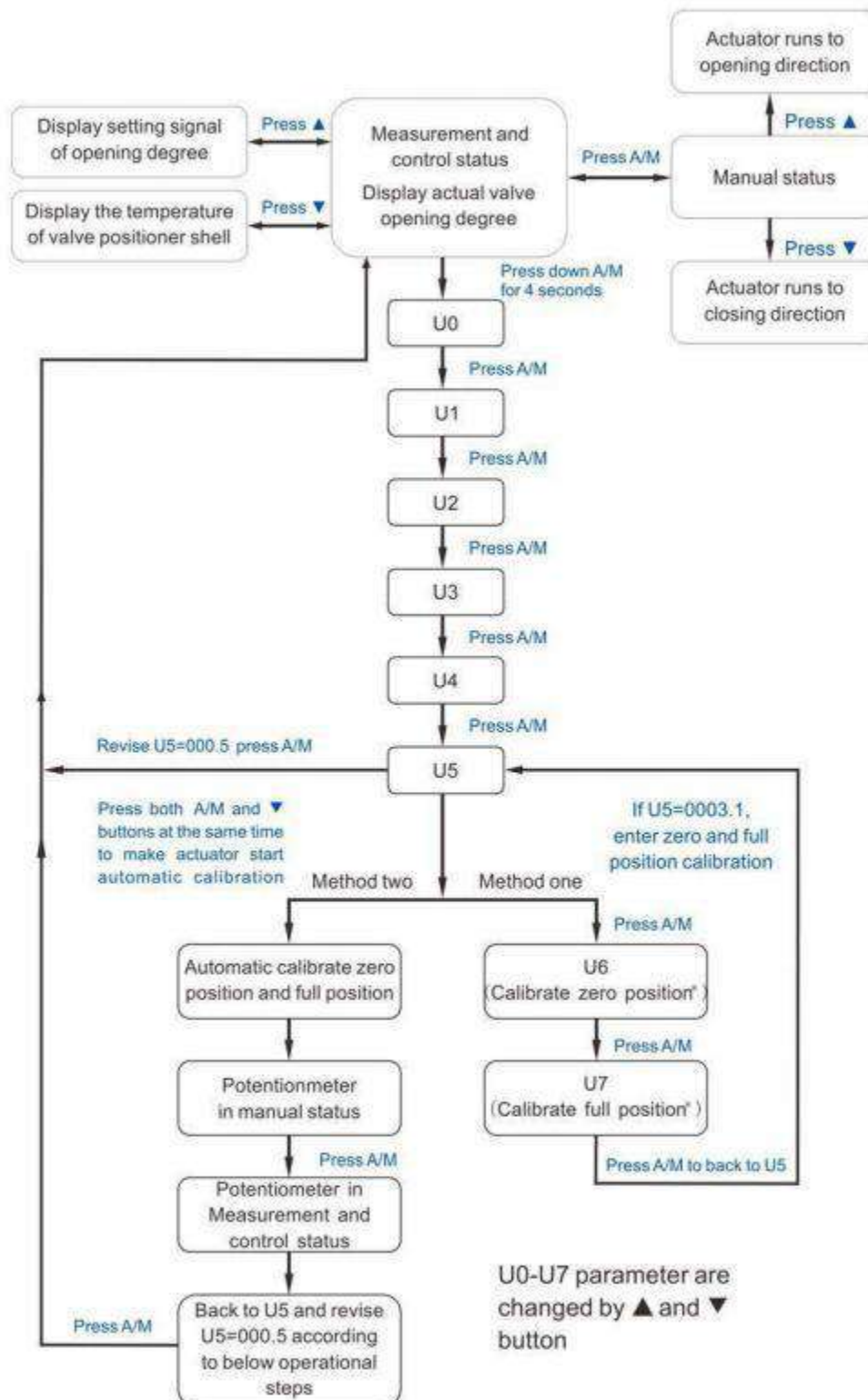

**NOTE:** Each parameters of regulation type actuator have already been calibrated before leaving factory. Do not alter it unless it must. If really do, please read it carefully before commissioning.



### 5. Error message and solution

Error Code	Meaning
E-01	For example, the signal of zero position is calibrate to be 4mA, but the given current 3.0mA. The actuator will start signal interrupt handler and show E-01 in screen
E-03	① Signal feedback lines of valve <u>positioner</u> and actuator are inversely connected ② Switch lines are inversely connect
E-05	The actuator has large oscillation because of input signal or feedback signal unstable, too high precision, etc
E-06	The actuator isn't able to open direction
E-07	The actuator isn't able to run to shut direction
E-08	The Internal temperature of <u>positioner</u> is higher than 80°C

### Maintenance

- ① No extra oil required because the molybdenum grease we put are with long service life and high withstand voltage.
- ② Please take periodical inspection to the actuator if you don't use it frequently.

### Troubleshooting

Fault phenomenon	Possible reason	Solution
Motor does not start	Lacking of power supply	Connect the actuator to power supply
	Electric wire broken, wiring terminals loose	Repair the wire, tighten wiring terminals
	Supply voltage is wrong or below level	Check the voltage is correct or wrong
	Overheat protector activated (ambient temperature is too high, the valve is	Reduce ambient temperature, manually open/close the valve to see if it is working
	Limit switch <u>disfunction</u>	Replace the limit switch
	Capacitance doesn't start or running	Replace the capacitance
Opening & closing Indicator light doesn't light	Indicator light is broken	Replace the indicator light
	Limit switch <u>disfunction</u>	Replace the limit switch
	Adjusting of block <u>disfunction</u>	Readjustment
Opening degree changing constantly	Signal source has interference signal	Check input signal
	Voltage divider generated interference	Replace the potentiometer
	Voltage divider gear or opening gear loose	Tightening up the screws of gear

## ELECTRIC VALVE



## PNEUMATIC VALVE



**Pipeline system overall solution**