

# PNEUMATIC VALVE

## ONE STOP SERVICE FOR PIPE EQUIPMENT

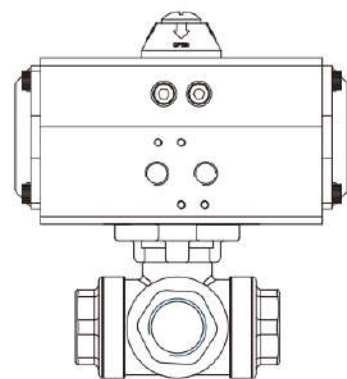
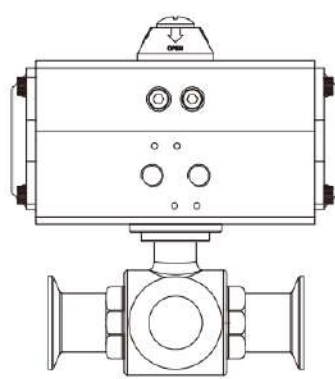
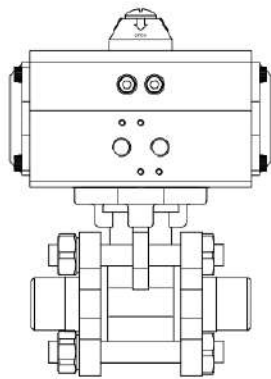
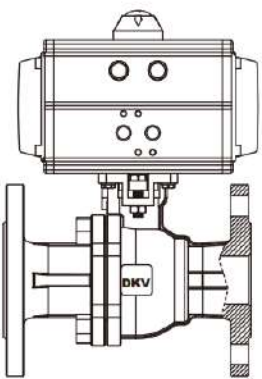

## Introduction

Quick open and close, less flowing resistance. PTFE sealing, perfect sealing, high temperature, corrosion resistance, acid and alkali resistance. The main features of the valve itself is compact, easy operation and maintenance for water, acids and natural gas general working media.

## Pneumatic Actuator

Double acting	Air to open, air to close, air supply failure to keep the current position
Single Acting N/C	Air to open, interrupt air to close, air failure to close
Single Acting N/O	Air to close, interrupt air to open, air failure to open
Optional accessory	Reversing solenoid valve, limit switch box, air filter reducing valve, positioner, handle manual, lock up valve



## Technical Parameters

Body		Valve components	
Nominal Size	DK15~DK400	Seat Material	PTFE: -30℃~180℃
Body Material	Flange	Core Material	SS304, SS316
Connection Type	Double union	Stem Material	SS304, SS316
Pressure Rating	PN1.0MPa PN1.6MPa	Applicable Medium	Water, Liquids, Gas, Oil, Powder, Steam, Acid-base Corrosive Medium.
Structure type	Floating ball core		

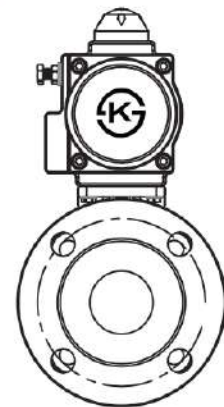

## Qutine Size drawing

UNIT: mm

MEDLE	DK15	DK20	DK25	DK32	DK40	DK50	DK65	DK80	DK100	DK125	DK150	DK200
G	1/2"	3/4"	1"	1-1/4"	1-1/2"	2"	2-1/2"	3"	4"	5"	6"	8"
D3	15	20	25	30	40	50	65	80	100	125	150	200
D2	45	55	65	78	85	100	120	135	155	185	210	265
D1	65	75	85	100	110	125	145	160	180	210	240	295
D	95	105	115	135	145	160	180	195	215	245	280	335
L	130	140	150	165	180	200	222	250	280	320	360	400
n-φd	4-φ14	4-φ14	4-φ14	4-φ18	4-φ18	4-φ18	4-φ18	8-φ18	8-φ18	8-φ18	8-φ28	4-φ23
Weight (Kg)	3.68	3.98	4.38	6.48	8.38	10.18	15.58	18.08	26.26	37.68	53.98	
Actuator	AT52	AT52	AT52	AT63	AT75	AT83	AT92	AT105	AT125	AT140	AT160	AT210

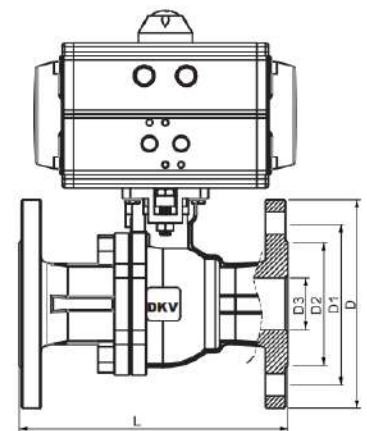

## Maintenance

- Tightening the seal between the valve and the actuator:  
Remove the four bolts underneath the actuator. Separate the actuator from the valve. Tighten the nut on the top of the valve body. Place the actuator back on the valve and screw everything back into place.
- Tightening the seals between the valve and the inlet/outlet ports:  
Remove the torque bolts and check for any debris or damage to the gaskets. Use a torque wrench or other consistent method of tightening the torque bolts to reconnect the inlet and outlet ports.

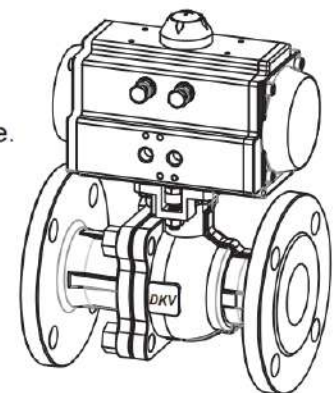



## Introduction

Quick open and close, less flowing resistance. PTFE sealing, perfect sealing, high temperature, corrosion resistance, acid and alkali resistance. The main features of the valve itself is compact, easy operation and maintenance for water, acids and natural gas general working media.

## Pneumatic Actuator

Double acting	Air to open, air to close, air supply failure to keep the current position
Single Acting N/C	Air to open, interrupt air to close, air failure to close
Single Acting N/O	Air to close, interrupt air to open, air failure to open
Optional accessory	Reversing solenoid valve, limit switch box, air filter reducing valve, positioner, handle manual, lock up valve

## Technical Parameters

Body		Valve components	
Nominal Size	DK15~DK400	Seat Material	PTFE: -30℃~180℃
Body Material	SS304, SS316, SS316L	Core Material	Ss304. SS316.SS316L
Connection Type	Double union	Stem Material	Ss304. SS316.SS316L
Pressure Rating	PN1.0MPa PN1.6MPa	Applicable Medium	Water, Liquids, Gas, Oil, Powder, Steam, Acid-base Corrosive Medium:
Structure type	Floating ball core		

## Qutine Size drawing (ANSI-150#)

UNIT: mm

MEDLE	DK15	DK20	DK25	DK32	DK40	DK50	DK65	DK80	DK100	DK125	DK150	DK200	DK250
G	1/2"	3/4"	1"	1-1/4"	1-1/2"	2"	2-1/2"	3"	4"	5"	6"	8"	10"
D3	15	20	25	30	40	50	65	80	100	125	150	200	250
D2	34.9	42.9	50.8	63.5	73	92.1	104.8	127	157.2	185.7	215.9	269.9	323.8
D1	60.3	69.9	79.4	88.9	98.4	120.7	139.7	152.4	190.5	215.9	241.3	298.5	362
D	90	100	110	115	125	150	180	190	230	255	280	345	405
L	108	117	127	140	165	178	190	203	229	356	394	457	533
b	11.5	13	14.5	16	17.5	19.5	22.5	24	24	24	25.5	29	30.5
n-φd	4-φ14	4-φ14	4-φ14	4-φ18	4-φ18	4-φ18	4-φ18	8-φ18	8-φ18	8-φ18	8-φ28	8-φ23	12-φ25
Actuator	AT52	AT52	AT52	AT63	AT75	AT83	AT92	AT105	AT125	AT140	AT160	AT210	At240

## Maintenance

- Tightening the seal between the valve and the actuator:  
Remove the four bolts underneath the actuator. Separate the actuator from the valve. Tighten the nut on the top of the valve body. Place the actuator back on the valve and screw everything back into place.
- Tightening the seals between the valve and the inlet/outlet ports:  
Remove the torque bolts and check for any debris or damage to the gaskets. Use a torque wrench or other consistent method of tightening the torque bolts to reconnect the inlet and outlet ports.

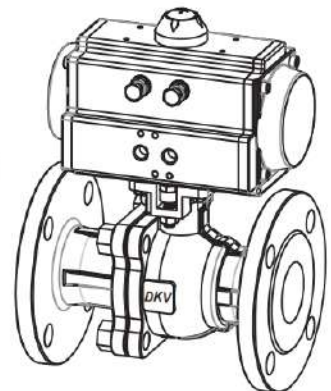
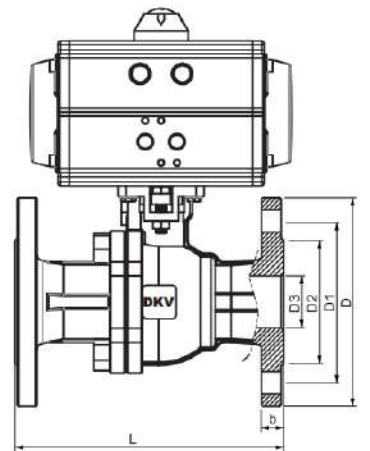
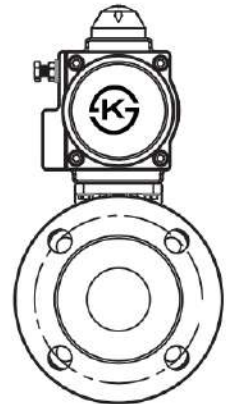

## Introduction

Quick open and close, less flowing resistance. PTFE sealing, perfect sealing, high temperature, corrosion resistance, acid and alkali resistance. The main features of the valve itself is compact, easy operation and maintenance for water, acids and natural gas general working media.

## Pneumatic Actuator

Double acting	Air to open, air to close, air supply failure to keep the current position
Single Acting N/C	Air to open, interrupt air to close, air failure to close
Single Acting N/O	Air to close, interrupt air to open, air failure to open
Optional accessory	Reversing solenoid valve, limit switch box, air filter reducing valve, positioner, handle manual, lock up valve

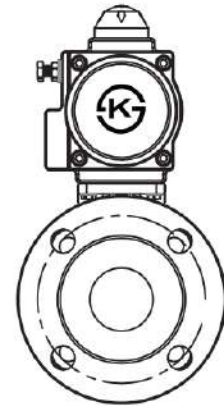

## Technical Parameters

Body		Valve components	
Nominal Size	DK15~DK400	Seat Material	PTFE: -30℃~180℃
Body Material	Ss304, SS316, SS316L	Core Material	Ss304, SS316, SS316L
Connection Type	Double union	Stem Material	Ss304, SS316, SS316L
Pressure Rating	PN1.0MPa PN1.6MPa	Applicable Medium	Water, Liquids, Gas, Oil, Powder, Steam, Acid-base Corrosive Medium:
Structure type	Floating ball core		

## Qutine Size drawing(JIS-10K)

UNIT: mm

MEDLE	DK 15	DK 20	DK 25	DK 32	DK 40	DK 50	DK 65	DK 80	DK 100	DK 125	DK 150	DK 200
G	1/2"	3/4"	1"	1-1/4"	1-1/2"	2"	2-1/2"	3"	4"	5"	6"	8"
D3	15	20	25	30	40	50	65	80	100	125	150	200
D2	52	58	70	80	85	100	120	130	155	185	215	265
D1	70	75	90	100	105	120	140	150	175	210	240	290
D	95	100	125	135	140	155	175	185	210	250	280	330
L	108	117	127	140	165	178	190	203	229	356	394	457
b	12	14	14	16	16	16	18	18	18	20	22	22
n-φd	4-φ15	4-φ15	4-φ19	4-φ19	4-φ19	4-φ19	4-φ19	8-φ19	8-φ19	8-φ23	8-φ23	12-φ25
Actuator	AT52	AT52	AT52	AT63	AT75	AT83	AT92	AT105	AT125	AT140	AT160	AT210

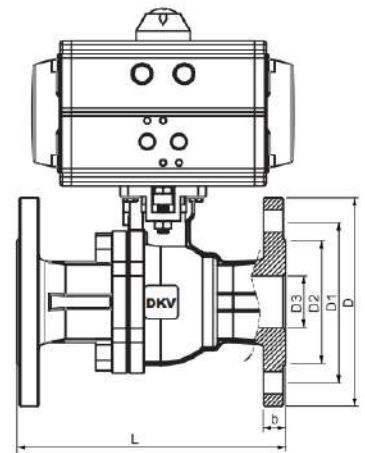

## Qutine Size drawing(JIS-20K)

UNIT: mm

MEDLE	DK 15	DK 20	DK 25	DK 32	DK 40	DK 50	DK 65	DK 80	DK 100	DK 125	DK 150	DK 200
G	1/2"	3/4"	1"	1-1/4"	1-1/2"	2"	2-1/2"	3"	4"	5"	6"	8"
D3	15	20	25	30	40	50	65	80	100	125	150	200
D2	52	58	70	80	85	100	120	135	160	195	230	275
D1	70	75	90	100	105	120	140	160	185	225	260	305
D	95	100	125	135	140	155	175	200	225	270	305	350
L	140	152	165	178	190	216	241	282	305	381	403	502
b	14	16	16	18	18	18	20	22	24	26	28	30
n-φd	4-φ15	4-φ15	4-φ19	4-φ19	4-φ19	8-φ19	8-φ19	8-φ23	8-φ23	8-φ25	12-φ25	12-φ25
Actuator	AT52	AT52	AT52	AT63	AT75	AT83	AT92	AT105	AT125	AT140	AT160	AT210

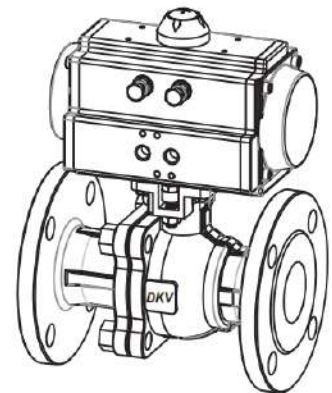



### Introduction

The 2 piece ball valve small size, large diameter, switch easy and convenient, reliable seal, simple structure, easy maintenance, sealing surface and sphere often closed state, not easy to be medium erosion, can be applied to water, gas, steam, oil, nitric acid, acetic acid and other media

### Pneumatic Actuator

Double acting	Air to open, air to close, air supply failure to keep the current position
Single Acting N/C	Air to open, interrupt air to close, air failure to close
Single Acting N/O	Air to close, interrupt air to open, air failure to open
Optional accessory	Reversing solenoid valve, limit switch box, air filter reducing valve, positioner, handle manual, lock up valve



### Technical Parameters

Body		Valve components	
Nominal Size	DN8-DN100	Seat Material	PTFE: -30°C~180°C PPL: -20°C~150°C
Body Material	SS304 SS316 SS316L	Core Material	Stainless Steel
End Connection	Female Thread	Stem Material	Stainless Steel
Operating Pressure	PN1.6MPa	Applicable Medium	Control of Water, Air, Gas, Oil, Liquid, Steam
Structure	Floating ball core		

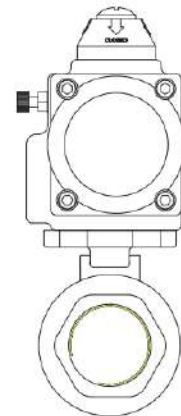

### Qutine Size drawing

UNIT: mm

MEDLE	DN08	DN10	DN15	DN20	DN25	DN32	DN40	DN50	DN65	DN80	DN100
G	1/4"	3/8"	1/2"	3/4"	1"	1-1/4"	1-1/2"	2"	2-1/2"	3"	4"
D	8	10	15	20	25	32	40	50	65	80	100
L	55	55	55	73	84	98	106	121	160	180	220
H	30	30	37	40	49	53	62	70	93	106	126

### Maintenance

- Tightening the seal between the valve and the actuator:  
Remove the four bolts underneath the actuator. Separate the actuator from the valve. Tighten the nut on the top of the valve body. Place the actuator back on the valve and screw everything back into place.
- Tightening the seals between the valve and the inlet/outlet ports:  
Remove the torque bolts and check for any debris or damage to the gaskets. Use a torque wrench or other consistent method of tightening the torque bolts to reconnect the inlet and outlet ports.

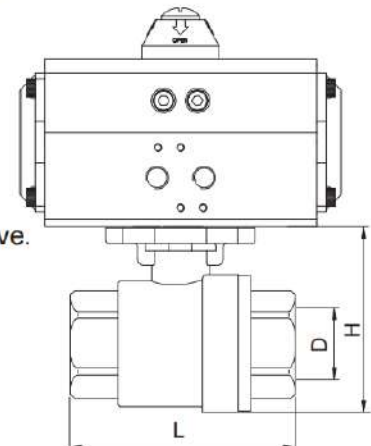

#### Introduction

The 3 piece design allows for the center part of the valve containing the ball, stem & seats to be easily removed from the pipeline. This facilitates efficient cleaning of deposited sediments, replacement of seats and gland packings, polishing out of small scratches on the ball, all this without removing the pipes from the valve body. The design concept of a three piece valve is for it to be repairable



#### Pneumatic Actuator

Double acting	Air to open, air to close, air supply failure to keep the current position
Single Acting N/C	Air to open, interrupt air to close, air failure to close
Single Acting N/O	Air to close, interrupt air to open, air failure to open
Optional accessory	Reversing solenoid valve, limit switch box, air filter reducing valve, positioner, handle manual, lock up valve

#### Technical Parameters

Body		Valve components	
Nominal Size	DN8-DN100	Seat Material	PTFE: -30 °C ~ 180 °C PPL : -20 °C ~ 250 °C
Body Material	SS304 SS316 SS316L	Core Material	SS304 SS316
Connection Type	Welded	Stem Material	SS304
Pressure Rating	PN1.0,2.5,4.0,6.4,31.5MPa	Applicable Medium	Water, Liquids, Gas, Oil, Powder, Steam, Acid-base Corrosive Medium.
Structure type	Floating ball core		

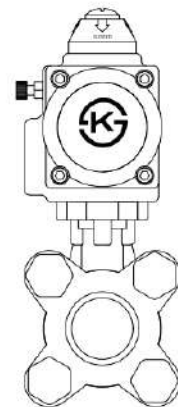

#### Qutine Size drawing

UNIT: mm

MEDLE	DN08	DN10	DN15	DN20	DN25	DN32	DN40	DN50	DN65	DN80	DN100
G	1/4"	3/8"	1/2"	3/4"	1"	1-1/4"	1-1/2"	2"	2-1/2"	3"	4"
d	10	12	15	20	25	32	40	50	65	80	100
D	12.5	17.5	22	27	34	42.5	48.5	61	73	90	115
L	65	65	75	83	90	113	115	140	160	180	215
H	33	34	38	45	55	60	70	85	100	112	140

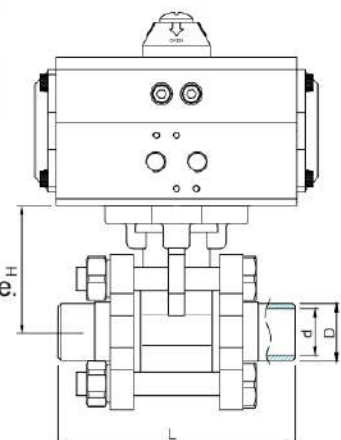

#### Maintenance

- Tightening the seal between the valve and the actuator:  
Remove the four bolts underneath the actuator. Separate the actuator from the valve. Tighten the nut on the top of the valve body. Place the actuator back on the valve and screw everything back into place.
- Tightening the seals between the valve and the inlet/outlet ports:  
Remove the torque bolts and check for any debris or damage to the gaskets. Use a torque wrench or other consistent method of tightening the torque bolts to reconnect the inlet and outlet ports.



#### Introduction

The 3 piece design allows for the center part of the valve containing the ball, stem & seats to be easily removed from the pipeline. This facilitates efficient cleaning of deposited sediments, replacement of seats and gland packings, polishing out of small scratches on the ball, all this without removing the pipes from the valve body. The design concept of a three piece valve is for it to be repairable.

#### Pneumatic Actuator

Double acting	Air to open, air to close, air supply failure to keep the current position
Single Acting N/C	Air to open, interrupt air to close, air failure to close
Single Acting N/O	Air to close, interrupt air to open, air failure to open
Optional accessory	Reversing solenoid valve, limit switch box, air filter reducing valve, positioner, handle manual, lock up valve



#### Technical Parameters

Body		Valve components	
Nominal Size	DN8-DN100	Seat Material	PTFE: -30°C~180°C PPL: -20°C~250°C
Body Material	SS304 SS316 SS316L	Core Material	SS304 SS316
Connection Type	Clamp	Stem Material	SS304
Pressure Rating	PN1.0,2.5,4.0,6.4,31.5MPa	Applicable Medium	Water, Liquids, Gas, Oil, Powder, Steam, Acid-base Corrosive Medium.
Structure type	Floating ball core		

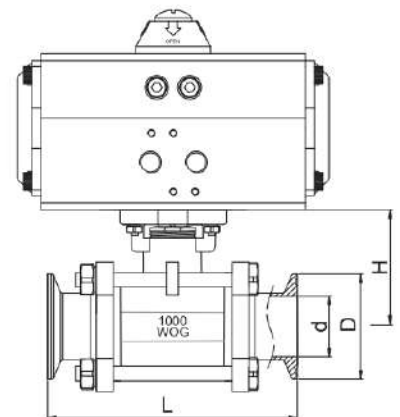
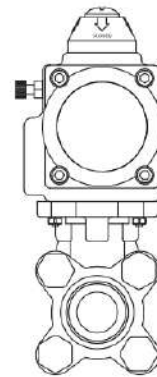

#### Qutine Size drawing

UNIT: mm

MEDLE	DN15	DN20	DN25	DN32	DN40	DN50	DN65	DN80	DN100
Actuator	AT52				AT63	AT75	AT83	AT92	AT92
G	1/2"	3/4"	1"	1-1/4"	1-1/2"	2"	2-1/2"	3"	4"
D	50.5	50.5	50.5	50.5	50.5	64	91	106	119
L	100	100	120	130	140	156	196	228	242
H	55	60	70	82	90	105	120	132	158

#### Maintenance

- Tightening the seal between the valve and the actuator:  
Remove the four bolts underneath the actuator. Separate the actuator from the valve. Tighten the nut on the top of the valve body.  
Place the actuator back on the valve and screw everything back into place.
- Tightening the seals between the valve and the inlet/outlet ports:  
Remove the torque bolts and check for any debris or damage to the gaskets. Use a torque wrench or other consistent method of tightening the torque bolts to reconnect the inlet and outlet ports.

### Introduction

The 3 piece design allows for the center part of the valve containing the ball, stem & seats to be easily removed from the pipeline. This facilitates efficient cleaning of deposited sediments, replacement of seats and gland packings, polishing out of small scratches on the ball, all this without removing the pipes from the valve body. The design concept of a three piece valve is for it to be repairable.

### Pneumatic Actuator

Double acting	Air to open, air to close, air supply failure to keep the current position
Single Acting N/C	Air to open, interrupt air to close, air failure to close
Single Acting N/O	Air to close, interrupt air to open, air failure to open
Optional accessory	Reversing solenoid valve, limit switch box, air filter reducing valve, positioner, handle manual, lock up valve

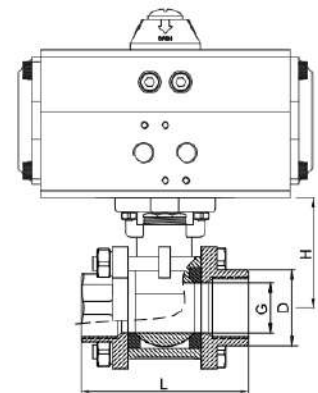
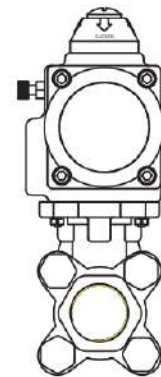

### Technical Parameters

Body		Valve components	
Nominal Size	DN8-DN100	Seat Material	PTFE: -30°C~180°C PPL: -20°C~250°C
Body Material	SS304 SS316 SS316L	Core Material	SS304 SS316
Connection Type	Female Thread	Stem Material	SS304
Pressure Rating	PN1.0,2.5,4.0,6.4,31.5MPa	Applicable Medium	Water, Liquids, Gas, Oil, Powder, Steam, Acid-base Corrosive Medium.
Structure type	Floating ball core		

### Qutine Size drawing

UNIT: mm

MEDLE	DN08	DN10	DN15	DN20	DN25	DN32	DN40	DN50	DN65	DN80	DN100
Actuator	AT52	AT52	AT52	AT52	AT52	AT65	AT65	AT75	AT83	AT92	AI92
G	1/4"	3/8"	1/2"	3/4"	1"	1-1/4"	1-1/2"	2"	2-1/2"	3"	4"
D	11.2	12.5	15	20	25	32	40	50	65	80	100
L	60	60	72	82	90	112	120	145	185	210	268
H	42	42	42	48.5	58.5	63	71	78	100	109	140
Weight (Kg)	2.1	2.1	2.1	2.1	2.4	3.6	4.2	5.4	8.7	14.6	18

### Maintenance

- Tightening the seal between the valve and the actuator:  
Remove the four bolts underneath the actuator. Separate the actuator from the valve. Tighten the nut on the top of the valve body. Place the actuator back on the valve and screw everything back into place.
- Tightening the seals between the valve and the inlet/outlet ports:  
Remove the torque bolts and check for any debris or damage to the gaskets. Use a torque wrench or other consistent method of tightening the torque bolts to reconnect the inlet and outlet ports.

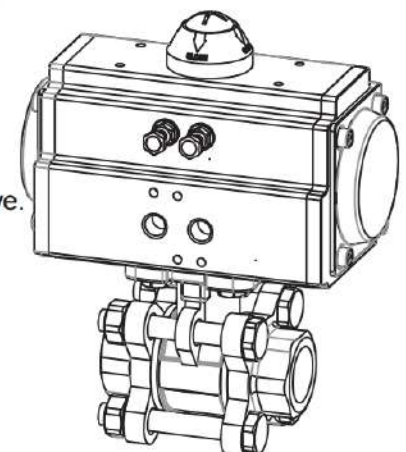



## Introduction

Ultra Low Torque, Elegant, Durable, Corrosion Resistance  
 Full Flow, PTFE Ball sealing, Low Torque Can Use the Handle Regulating Valve Seat Tightness Released By The Central Section Is Still Intact, Valves, Replaceable To Provide Supplementary Platform Embedded Copper Nut Products Convenient Automatic Actuator

## Pneumatic Actuator

Double acting	Air to open, air to close, air supply failure to keep the current position
Single Acting N/C	Air to open, interrupt air to close, air failure to close
Single Acting N/O	Air to close, interrupt air to open, air failure to open
Optional accessory	Reversing solenoid valve, limit switch box, air filter reducing valve, positioner, handle manual, lock up valve



## Technical Parameters

Body		Valve components	
Nominal Size	DN15-DN400	Seat Material	EPDM, PTFE
Body Material	Plastic UPVC	Core Material	Plastic UPVC
Connection Type	Double union	Stem Material	SS304, SS410
Pressure Rating	PN1.0MPa PN1.6MPa	Applicable Medium	Water, Liquids, Gas, Oil, Powder, Steam, Acid-base Corrosive Medium.
Structure type	Floating ball core		

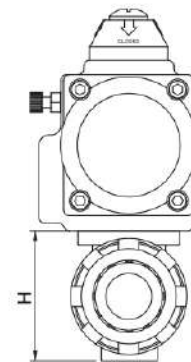

## Qutine Size drawing

UNIT: mm

MEDLE	DN15	DN20	DN25	DN32	DN40	DN50	DN65	DN80	DN100
G	1/2"	3/4"	1"	1-1/4"	1-1/2"	2"	2-1/2"	3"	4"
d	14	20	25	30	38	50	63	78	100
D	20	25	32	40	50	63	75	90	110
D1	30	36	45	55	64	77	96	112	141
L1	22.8	25	28.5	32	34.8	39	46	48	64.5
L	121.8	134.5	150.2	166.8	179	205	233	257	309
H	61	74	90	104	121	146	169	220	255
Weight (Kg)	1.68	1.78	1.93	2.16	3.68	4.28	5.78	9.38	13.88
Actuator	AT52	AT52	AT52	AT52	AT63	AT63	AT75	AT83	AT105

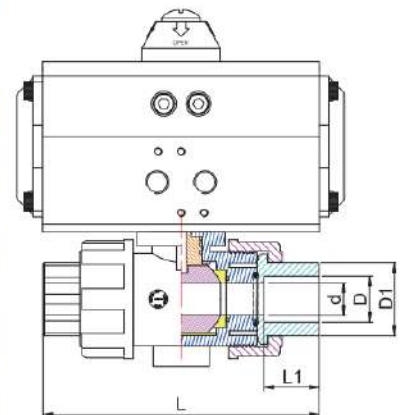

## Maintenance

- Tightening the seal between the valve and the actuator:  
 Remove the four bolts underneath the actuator. Separate the actuator from the valve. Tighten the nut on the top of the valve body. Place the actuator back on the valve and screw everything back into place.
- Tightening the seals between the valve and the inlet/outlet ports:  
 Remove the torque bolts and check for any debris or damage to the gaskets. Use a torque wrench or other consistent method of tightening the torque bolts to reconnect the inlet and outlet ports.

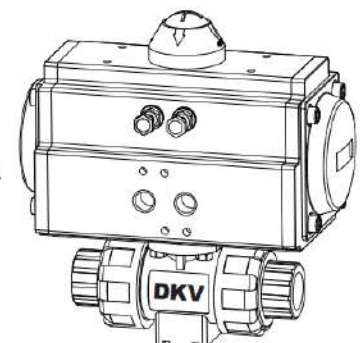

#### Introduction

The 3 piece design allows for the center part of the valve containing the ball, stem & seats to be easily removed from the pipeline. This facilitates efficient cleaning of deposited sediments, replacement of seats and gland packings, polishing out of small scratches on the ball, all this without removing the pipes from the valve body. The design concept of a three piece valve is for it to be repairable.

#### Pneumatic Actuator

Double acting	Air to open, air to close, air supply failure to keep the current position
Single Acting N/C	Air to open, interrupt air to close, air failure to close
Single Acting N/O	Air to close, interrupt air to open, air failure to open
Optional accessory	Reversing solenoid valve, limit switch box, air filter reducing valve, positioner, handle manual, lock up valve



#### Technical Parameters

Body		Valve components	
Nominal Size	DN15-DN100	Seat Material	PTFE: -30r-180 C PPL: -30°C -250 C
Body Material	SS304.SS316.SS316L	Disc Material	SS304, SS316, SS316L
Connection Type	Clamp, Welding	Stem Material	SS304
Pressure Rating	PN1.6MPa	Design Standard	ISO、DIN、IDF、SMS、3A
Structure type	Floating ball core 3 way L-type/ T-type ball valve	Applicable Medium	Food, Medicine, Packaging Machinery, Filling Machinery And Other Health Conditions Using Level.

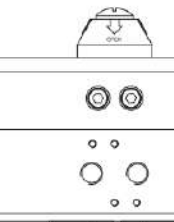
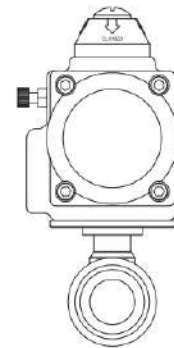

#### Qutine Size drawing

UNIT: mm

Size	Ø19	Ø25	Ø32	Ø38	Ø51	Ø63	Ø76	Ø89	Ø102
DN	DN15	DN20	DN25	DN32	DN40	DN50	DN65	DN80	DN100
d	16	21	29	35	47	59	72	85	97
D	50,5	50,5	50,5	50,5	64	77.5	91	106	119
L	102	117	123	140	180	200	220	235	275
Actuator	AT52		AT63		AT75	AT83	AT92	AT92	AT105
Weight (Kg)	2.08	2.18	2.23	2.91	4.68	5.88	8.78	11.38	14.78

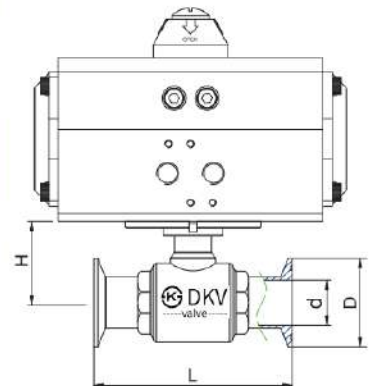

#### Maintenance

- Tightening the seal between the valve and the actuator:  
Remove the four bolts underneath the actuator. Separate the actuator from the valve. Tighten the nut on the top of the valve body. Place the actuator back on the valve and screw everything back into place.
- Tightening the seals between the valve and the inlet/outlet ports:  
Remove the torque bolts and check for any debris or damage to the gaskets. Use a torque wrench or other consistent method of tightening the torque bolts to reconnect the inlet and outlet ports.



## Introduction

Ultrahigh pressure ball is adopt ball core rotate 90 degrees to open or close the valve, the brick, high pressure forging with German import seal assembly, provided by initial seal, stainless steel butterfly spring cushion packing seal surface enhanced with medium pressure rise, self sealing performance is strong, super high pressure ball valve can be used in the ultra high pressure liquid, ultrahigh pressure gas or the mixture of main application industry has ultrahigh pressure testing machine, pneumatic pumps, hydraulic pump, deep-sea detectors.

## Pneumatic Actuator

Double acting	Air to open, air to close, air supply failure to keep the current position
Single Acting N/C	Air to open, interrupt air to close, air failure to close
Single Acting N/O	Air to close, interrupt air to open, air failure to open
Optional accessory	Reversing solenoid valve, limit switch box, air filter reducing valve, positioner, handle manual, lock up valve



## Technical Parameters

Body		Valve components	
Nominal Size	DN08-DN50	Seat Material	PTFE:-20°C~180°C
Body Material	SS304 SS316 SS316 L	Core Material	Stainless Steel
Connection Type	Thread	Stem Material	Stainless Steel
Pressure Rating	PN10.0~40.0MPa	Applicable Medium	Ultra high pressure liquid, Ultra high pressure gas, Oil Or a mixture thereof.
Structure type	Floating ball core		

## Qutine Size drawing

UNIT: mm

MEDLE	DN08	DN10	DN15	DN20	DN25	DN32	DN40	DN50
G	1/4"	3/8"	1/2"	3/4"	1"	1-1/4"	1-1/2"	2"
D	6	8	10	14.6	19.6	24.8	30	39.6
B	33	35	37	45	55	88	102	113
L	69	72	83	95	113	120	131	142
H	13	16	18	24	32	38	42	50
H1	176	176	176	237	237	249	285	348

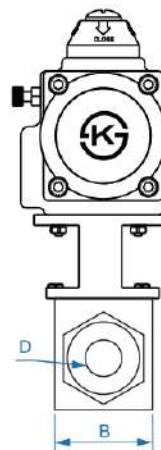

## Maintenance

- Tightening the seal between the valve and the actuator:  
Remove the four bolts underneath the actuator. Separate the actuator from the valve. Tighten the nut on the top of the valve body. Place the actuator back on the valve and screw everything back into place.
- Tightening the seals between the valve and the inlet/outlet ports:  
Remove the torque bolts and check for any debris or damage to the gaskets. Use a torque wrench or other consistent method of tightening the torque bolts to reconnect the inlet and outlet ports.

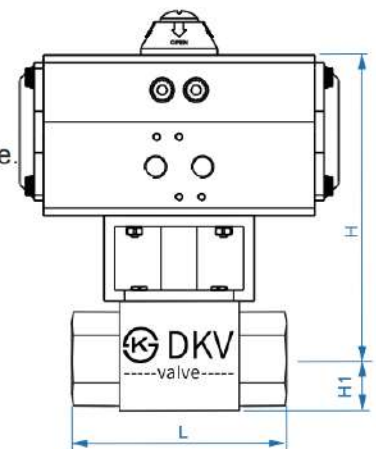

## Introduction

The 3 piece design allows for the center part of the valve containing the ball, stem & seats to be easily removed from the pipeline. This facilitates efficient cleaning of deposited sediments, replacement of seats and gland packings, polishing out of small scratches on the ball, all this without removing the pipes from the valve body. The design concept of a three piece valve is for it to be repairable.

## Pneumatic Actuator

Double acting	Air to open, air to close, air supply failure to keep the current position
Single Acting N/C	Air to open, interrupt air to close, air failure to close
Single Acting N/O	Air to close, interrupt air to open, air failure to open
Optional accessory	Reversing solenoid valve, limit switch box, air filter reducing valve, positioner, handle manual, lock up valve



## Technical Parameters

Body		Valve components	
Size Range	DN08-DN100	Body Material	Stainless Steel
Operating Pressure	1.0MPa-6.4MPa	Core Material	Stainless Steel
End Connection	Threaded, Butt Welded	Sealing Material	ptfe:-30°C~180°C PPL:-30°C~250°C
Structure	3 Way L-port/ T-port	Applicable Media	Control of Water, Air, Gas, Oil, Liquid, Steam

T-Pattern Flow Direction Diagram

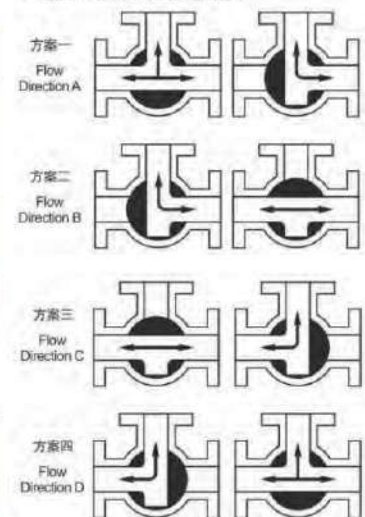

L-Pattern Flow Direction Diagram

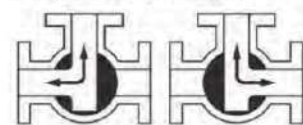

## Qutine Size drawing

UNIT: mm

MEDLE	DN15	DN20	DN25	DN32	DN40	DN50	DN65	DN80	DN100
Actuator	AT52		AT63		AT75	AT83	AT105	AT125	
G	1/2"	3/4"	1"	1-1/4"	1-1/2"	2"	2-1/2"	3"	4"
D	15	20	25	32	40	50	65	80	100
L	72	85	90	117	136	151			
H	37	39	48	57	68	78			
Weight (Kg)	1.98	2.08	2.38	5.18	5.98	7.1	15.88		

## Maintenance

- Tightening the seal between the valve and the actuator:  
Remove the four bolts underneath the actuator. Separate the actuator from the valve. Tighten the nut on the top of the valve body. Place the actuator back on the valve and screw everything back into place.
- Tightening the seals between the valve and the inlet/outlet ports:  
Remove the torque bolts and check for any debris or damage to the gaskets. Use a torque wrench or other consistent method of tightening the torque bolts to reconnect the inlet and outlet ports.

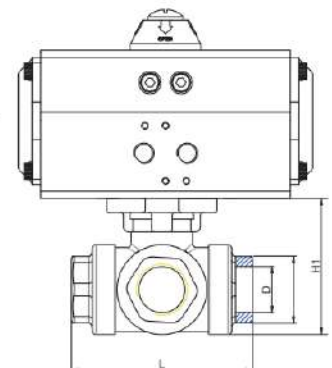



## Introduction

Quick open and close, less flowing resistance. PTFE sealing, perfect sealing, high temperature, corrosion resistance, acid and alkali resistance. The main features of the valve itself is compact, easy operation and maintenance for water, acids and natural gas general working media.



## Pneumatic Actuator

Double acting	Air to open, air to close, air supply failure to keep the current position
Single Acting N/C	Air to open, interrupt air to close, air failure to close
Single Acting N/O	Air to close, interrupt air to open, air failure to open
Optional accessory	Reversing solenoid valve, limit switch box, air filter reducing valve, positioner, handle manual, lock up valve

## Technical Parameters

Body		Valve components	
Size Range	DK15~DK400	Body Material	Stainless Steel, WCB
Operating Pressure	Flange	Core Material	Stainless Steel, WCB
End Connection	Double union	Sealing Material	PTFE: -30°C~180°C PPL: -30°C~250°C
Structure	PN1.0MPa PN1.6MPa	Applicable Media	Control of Water, Air, Gas, Oil, Liquid, Steam

T-Pattern Flow Direction Diagram



L-Pattern Flow Direction Diagram

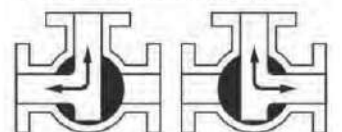

## Qutine Size drawing

MEDLE	DK 15	DK20	DK25	DK32	DK40	DK 50	DK65	DK80	DK100	DK 125	DK150	DK 200
G	1/2"	3/4"	1"	1-1/4"	1-1/2"	2"	2-1/2"	3"	4"	5"	6"	8"
D3	15	20	25	30	40	50	65	80	100	125	150	200
D2	45	55	65	78	85	100	120	135	155	185	210	265
D1	65	75	85	100	110	125	145	160	180	210	240	295
D	95	105	115	135	145	160	180	195	215	245	280	335
L	150	164	180	200	220	240	260	280	320	380	440	550
H	53	58.5	70	77.5	88.5	92	107	119	150	200	240	300
B	72	80	90	100	110	120	130	140	160	190	220	260
n-φd	4-φ14	4-φ14	4-φ14	4-φ18	4-φ18	4-φ18	4-φ18	8-φ18	8-φ18	8-φ18	8-φ28	4-φ23
Actuator	AT63	AT63	AT63	AT75	AT83	AT92	AT105	AT125	AT140	AT160		

## Maintenance

- T-Tightening the seal between the valve and the actuator:  
Remove the four bolts underneath the actuator.  
Separate the actuator from the valve.  
Tighten the nut on the top of the valve body.  
Place the actuator back on the valve and screw everything back into place.
- Tightening the seals between the valve and the inlet/outlet ports: Remove the torque bolts and check for any debris or damage to the gaskets. Use a torque wrench or other consistent method of tightening the torque bolts to reconnect the inlet and outlet ports.

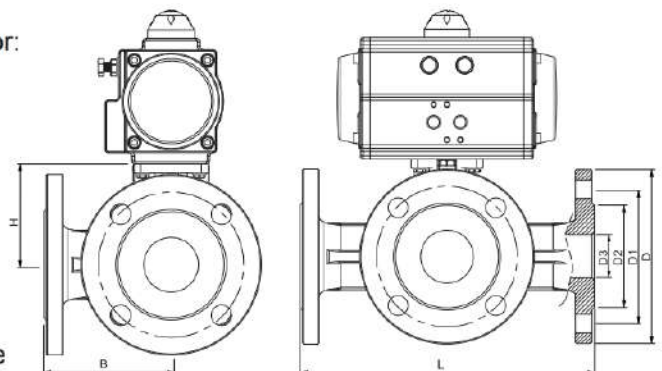

## Introduction

Ultra Low Torque, Elegant, Durable, Corrosion Resistance Full Flow, PTFE Ball sealing, Low Torque Can Use the Handle Regulating Valve Seat Tightness Released By The Central Section Is Still Intact. Valves, Replaceable To Provide Supplementary Platform Embedded Copper Nut Products Convenient Automatic Actuator

## Pneumatic Actuator

Double acting	Air to open, air to close, air supply failure to keep the current position
Single Acting N/C	Air to open, interrupt air to close, air failure to close
Single Acting N/O	Air to close, interrupt air to open, air failure to open
Optional accessory	Reversing solenoid valve, limit switch box, air filter reducing valve, positioner, handle manual, lock up valve



## Technical Parameters

Body		Valve components	
Nominal Size	DN15~DN50	Seat Material	EPDM, PTFE
Body Material	Plastic UPVC	Core Material	Plastic UPVC
Connection Type	Double union	Stem Material	SS304, SS410
Pressure Rating	PN1.0MPa PN1.6MPa	Applicable Medium	Water, Liquids, Gas, Oil, Powder, Steam, Acid-base Corrosive Medium.
Structure type	Floating ball core 3 way L-type/T-type ball valve		

T-Pattern Flow Direction Diagram

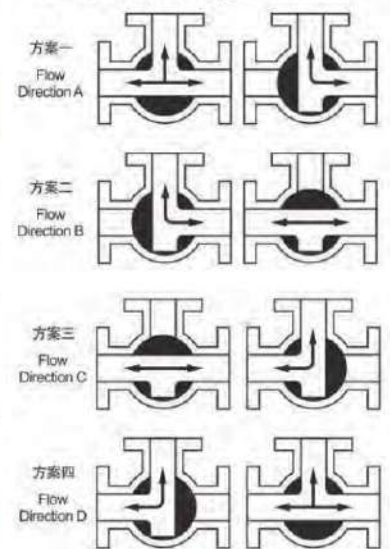

## Qutine Size drawing

UNIT: mm

MEDLE	DN15	DN20	DN25	DN32	DN40	DN50
G	1/2"	3/4"	1"	1-1/4"	1-1/2"	2"
d	14	20	25	30	38	50
D	20	25	32	40	50	63
D1	30	36	45	55	64	77
L1	22.8	25	28.5	32	34.8	39
L	163	172	200	208	240	246
H	69	69	72	72	110	110
Weight (Kg)	4.2	4.3	4.9	5.1	7.7	8.1
Actuator	AT52	AT52	AT63	AT63	AT75	AT83

## Maintenance

- Tightening the seal between the valve and the actuator:  
Remove the four bolts underneath the actuator. Separate the actuator from the valve. Tighten the nut on the top of the valve body.  
Place the actuator back on the valve and screw everything back into place.
- Tightening the seals between the valve and the inlet/outlet ports:  
Remove the torque bolts and check for any debris or damage to the gaskets.  
Use a torque wrench or other consistent method of tightening the torque bolts to reconnect the inlet and outlet ports.

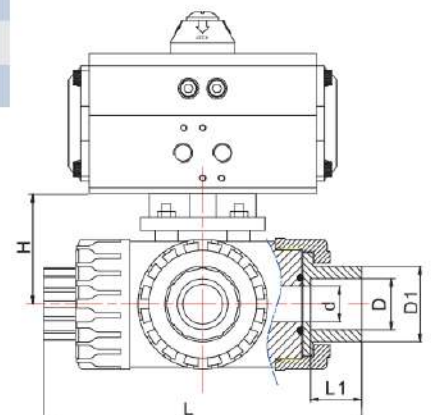



## Introduction

Sanitary pneumatic 3 way ball valves has been through the sophisticated inspection process and strict quality management. Using internal and external polishing and sterilization. Clamp quick connection, all-inclusive seal, easy to disassemble, cleaning and maintenance. Three-way sanitary ball valve for sanitary pipelines medium commutation, diversion, confluence, mixed flow. They can be manually operated or automated with an electric or pneumatic actuator.



## Pneumatic Actuator

Double acting	Air to open, air to close, air supply failure to keep the current position
Single Acting N/C	Air to open, interrupt air to close, air failure to close
Single Acting N/O	Air to close, interrupt air to open, air failure to open
Optional accessory	Reversing solenoid valve, limit switch box, air filter reducing valve, positioner, handle manual, lock up valve

## Technical Parameters

Body		Valve components	
Nominal Size	DN15-DN100	Seat Material	EPDM, PTFE
Body Material	SS304, SS316, SS316L	Core Material	Plastic UPVC
Connection Type	Clamp, Welding	Stem Material	SS304, SS410
Pressure Rating	PN1.6MPa	Design Standard	ISO, DIN, IDF, SMS, 3A
Structure type	Floating ball core 3 way L-type/ T-type ball valve	Applicable Medium	Food, Medicine, Packaging Machinery, Filling Machinery And Other Health Conditions Using Level.

T-Pattern Flow Direction Diagram

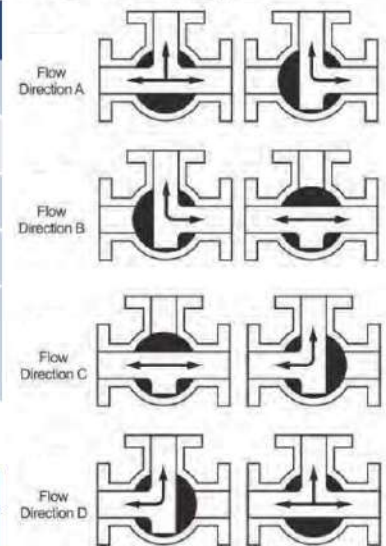

L-Pattern Flow Direction Diagram



## Outline Size drawing

UNIT: mm

Size	Ø19	Ø25	Ø32	Ø38	Ø51	Ø63	Ø76	Ø89	Ø102
DN	DN15	DN20	DN25	DN32	DN40	DN50	DN65	DN80	DN100
d	16	22	29	35	48	59	72	85	98
D	50.5	50.5	50.5	50.5	64	77.5	91	106	119
L	105	126	138	155	186	200	220	240	268
H	45	48	52.5	65	74	84	102	112	122
B	60	61.5	69	77	91	109	122	135	150
Actuator	AT52	AT52	AT52	AT63	AT75	AT83	AT105	AT125	AT125
Weight (kg)	2.23	2.38	2.68	3.88	5.58	6.22	12.88	15.5	18.58

## Maintenance

- Tightening the seal between the valve and the actuator: Remove the four bolts underneath the actuator. Separate the actuator from the valve. Tighten the nut on the top of the valve body. Place the actuator back on the valve and screw everything back into place.
- Tightening the seals between the valve and the inlet/outlet ports: Remove the torque bolts and check for any debris or damage to the gaskets. Use a torque wrench or other consistent method of tightening the torque bolts to reconnect the inlet and outlet ports.

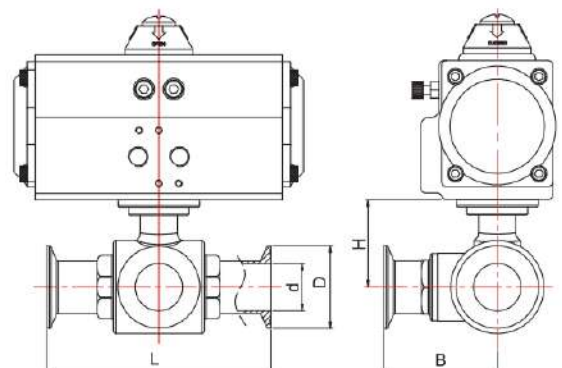

## Introduction

Ultrahigh pressure ball is adopt ball core rotate 90 degrees to open or close the valve, the brick, high pressure forging with German import seal assembly, provided by initial seal, stainless steel butterfly spring cushion packing seal surface enhanced with medium pressure rise, self sealing performance is strong, super high pressure ball valve can be used in the ultra high pressure liquid, ultrahigh pressure gas or the mixture of main application industry has ultrahigh pressure testing machine, pneumatic pumps, hydraulic pump, deep-sea detectors.



## Pneumatic Actuator

Double acting	Air to open, air to close, air supply failure to keep the current position
Single Acting N/C	Air to open, interrupt air to close, air failure to close
Single Acting N/O	Air to close, interrupt air to open, air failure to open
Optional accessory	Reversing solenoid valve, limit switch box, air filter reducing valve, positioner, handle manual, lock up valve

## Technical Parameters

Body		Valve components	
Size Range	DK08-DK50	Seating Material	PTFE:-20°C~180°C
Body Material	SS304 SS316 SS316 L	Core Material	Stainless Steel
End Connection	Female Thread	Stem Material	Stainless Steel
Operating Pressure	PN10.0-40.0MPa	Applicable Medium	Ultra high pressure liquid, Ultra high pressure gas, Oil Or a mixture thereof
Structure	Floating ball core		

## Qutine Size drawing

UNIT: mm

MEDLE	DK08	DK10	DK15	DK20	DK25	DK32	DK40	DK50
G	1/4"	3/8"	1/2"	3/4"	1"	1-1/4"	1-1/2"	2"
D	8	10	15	20	25	32	40	50
B	64	64	65	80	95	107	123	
H	43	43	43	53	64	70	79	
L	80	80	82	101	120	127	150	
L1	19	19	20	25	29	30	28	
L2	19	19	20	25	29	30	28	

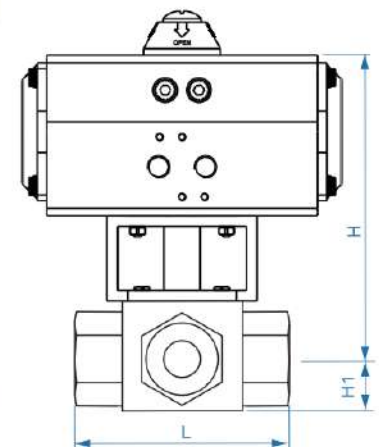
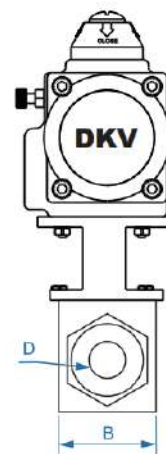

## Maintenance

- Tightening the seal between the valve and the actuator:  
Remove the four bolts underneath the actuator. Separate the actuator from the valve. Tighten the nut on the top of the valve body.  
Place the actuator back on the valve and screw everything back into place.
- Tightening the seals between the valve and the inlet/outlet ports:  
Remove the torque bolts and check for any debris or damage to the gaskets.  
Use a torque wrench or other consistent method of tightening the torque bolts to reconnect the inlet and outlet ports.



## Introduction

Pvc plastic butterfly valve according to the different medium has a variety of optional material, corrosive resistance is strong, adapt to large diameter,small volume, light weight, health non-toxic material, easy maintenance and replacement.

## Pneumatic Actuator

Double acting	Air to open, air to close, air supply failure to keep the current position
Single Acting N/C	Air to open, interrupt air to close, air failure to close
Single Acting N/O	Air to close, interrupt air to open, air failure to open
Optional accessory	Reversing solenoid valve, limit switch box, air filter reducing valve, positioner, handle manual, lock up valve



## Technical Parameters

Valve Body		Valve Components	
Size Range	DK50~DK600	Body Material	UPVC, CPVC, RPP, PVDF
Operating Pressure	1.0MPa	Stem Material	UPVC, CPVC, RPP, PVDF
End Connection	Wafer, Flange	Sealing Material	EPDM, NBR
Structure	Midline Structure A Type	Applicable Media	Compatible PVC Food Industry Chemical Solvents

## Qutine Size drawing

UNIT: mm

MEDLE	DK 50	DK65	DK80	DK100	DK 125	DK150	DK200	DK250	DK300	DK350	DK400	DK500
Inch	2"	2-1/2"	3"	4"	5"	6"	8"	10"	12"	14"	16"	20"
D	52.7	64.4	83	104.2	123.3	157	202.5	250.5	301.6	333.3	389.6	491.6
D1	165	185	200	220	250	285	340	395	445	505	565	670
D2	125	145	160	180	210	240	295	355	410	470	525	620
D3	99	118	132	156	184	211	266	319	370	429	480	582
L	108	112	114	127	140	140	150	165	185	195	216	229
H	192	207	224	255	290	325	386	460	510	565	632	759
n-φd	4-φ18	4-φ18	8-φ18	8-φ18	8-φ18	8-φ22	8-φ22	12-φ22	12-φ22	16-φ22	16-φ26	20-φ26
Weight (Kg)	2.36	2.66	3.76	4.96	7.5	9.26	13.14					

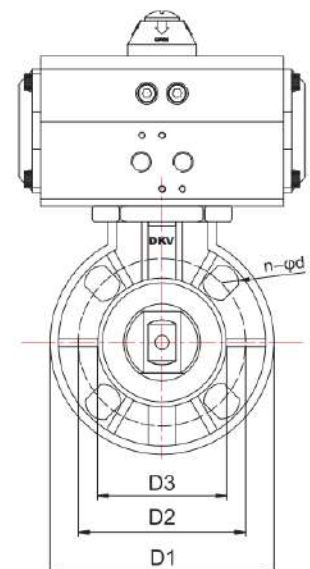
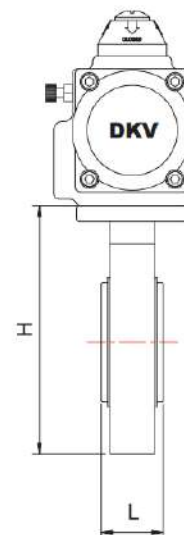

## Maintenance

- Tightening the seal between the valve and the actuator:  
Remove the four bolts underneath the actuator. Separate the actuator from the valve.  
Tighten the nut on the top of the valve body.  
Place the actuator back on the valve and screw everything back into place.
- Tightening the seals between the valve and the inlet/outlet ports:  
Remove the torque bolts and check for any debris or damage to the gaskets.  
Use a torque wrench or other consistent method of tightening the torque bolts to reconnect the inlet and outlet ports.

## Introduction

According to the sealing performance, pneumatic butterfly valve can be divided into metal seal and soft seal type. Advantages pneumatic butterfly valve over other type valves may include: compact structure, miniature size, long service life, good sealing performance, easy maintenance, quick detachable and installation.

## Pneumatic Actuator

Double acting	Air to open, air to close, air supply failure to keep the current position
Single Acting N/C	Air to open, interrupt air to close, air failure to close
Single Acting N/O	Air to close, interrupt air to open, air failure to open
Optional accessory	Reversing solenoid valve, limit switch box, air filter reducing valve, positioner, handle manual, lock up valve



## Technical Parameters

Body		Valve components	
Size Range	DK50~DK600	Seating Material	NBR, EPDM, VITON, PTFE
Body material	Ductile Iron	Disc Material	Stainless Steel , Ductile Iron
End Connection	Wafer Flange	Stem Material	Stainless Steel 316L
Operating Pressure	< 1.6MPa	Applicable media	Control of Water, Air, Gas, Oil, Liquid, Steam
Structure	Midline Structure / A-type		

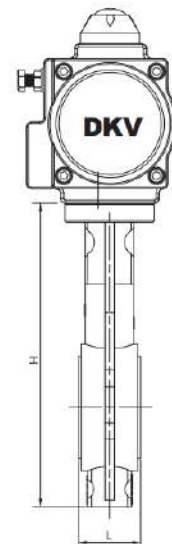

## Qutine Size drawing

UNIT: mm

MEDLE	DK50	DK65	DK80	DK100	DK125	DK150	DK200	DK250	DK300	DK350	DK400	DK500	DK600
Inch	2"	2-1/2"	3"	4"	5"	6"	8"	10"	12"	14"	16"	20"	24"
D	50	65	80	100	125	150	200	250	300	350	400	500	600
D1	96	104	127	153	180	206	270	320	368	428	482	605	
D2	125	145	160	180	210	240	295	355	410	470	525	650	725
L	45	47	48	58	59	59	64	70	78	80	108	120	152
H	212	225	256	280	315	345	405	480	554				
n-φd	4-φ18	4-φ18	4-φ18	4-φ18	4-φ18	4-φ23	4-φ23	4-φ23	4-φ26	4-φ26	4-φ26	4-φ30	4-φ36

## Maintenance

- Tightening the seal between the valve and the actuator:  
Remove the four bolts underneath the actuator. Separate the actuator from the valve.  
Tighten the nut on the top of the valve body.  
Place the actuator back on the valve and screw everything back into place.
- Tightening the seals between the valve and the inlet/outlet ports:  
Remove the torque bolts and check for any debris or damage to the gaskets.  
Use a torque wrench or other consistent method of tightening the torque bolts to reconnect the inlet and outlet ports.

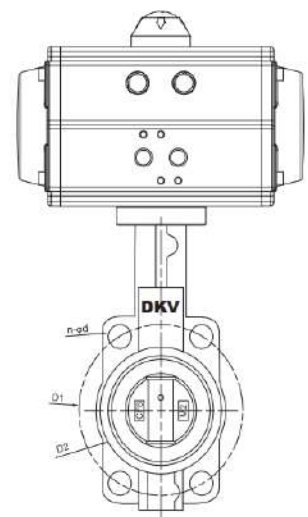



## Introduction

According to the sealing performance, pneumatic butterfly valve can be divided into metal seal and soft seal type. Advantages pneumatic butterfly valve over other type valves may include: compact structure, miniature size, long service life, good sealing performance, easy maintenance, quick detachable and installation.

## Pneumatic Actuator

Double acting	Air to open, air to close, air supply failure to keep the current position
Single Acting N/C	Air to open, interrupt air to close, air failure to close
Single Acting N/O	Air to close, interrupt air to open, air failure to open
Optional accessory	Reversing solenoid valve, limit switch box, air filter reducing valve, positioner, handle manual, lock up valve



## Technical Parameters

Body		Valve components	
Size Range	DN50-DN600	Seating Material	NBR, EPDM, VITON, PTFE
Body material	Stainless Steel	Disc Material	Stainless Steel
End Connection	Wafer Flange	Stem Material	Stainless Steel
Operating Pressure	< 1.6MPa	Applicable media	Control of Water, Air, Gas, Oil, Liquid, Steam
Structure	Midline Structure / A-type		

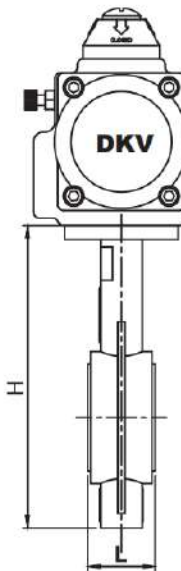

## Qutine Size drawing

UNIT: mm

MEDLE	DN50	DN65	DN80	DN100	DN125	DN150	DN200	DN250	DN300	DN350	DN400	DN500
Inch	2"	2-1/2"	3"	4"	5"	6"	8"	10"	12"	14"	16"	20"
D	52.7	64.4	78.8	104.2	123.3	157	202.5	250.5	301.6	333.3	389.6	491.6
D1	89	104	127	153	180	206	270	320	368	428	482	605
D2	125	145	160	180	210	240	295	355	410	470	525	585
L	41	43	45	50	54	54	60	66	75.5	86.5	86.5	131.8
H	207	219	232	262	265	296	353	390	460	508	597	677
n-φd	4-φ18	4-φ18	4-φ18	4-φ18	4-φ18	4-φ23	4-φ23	4-φ23	4-φ26	4-φ26	4-φ26	4-φ30
Weight (Kg)	3.48	4.68	5.28	7.08	8.88	11.68	16.88	23.5	31.8			
Actuator	AT52	AT52	AT63	AT75	AT83	AT92	AT115	AT125	AT140			

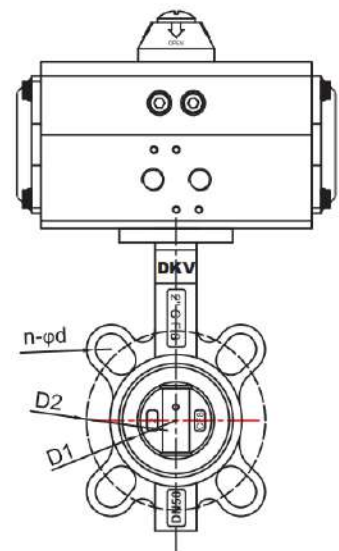

## Maintenance

- Tightening the seal between the valve and the actuator:  
Remove the four bolts underneath the actuator. Separate the actuator from the valve. Tighten the nut on the top of the valve body. Place the actuator back on the valve and screw everything back into place.
- Tightening the seals between the valve and the inlet/outlet ports:  
Remove the torque bolts and check for any debris or damage to the gaskets. Use a torque wrench or other consistent method of tightening the torque bolts to reconnect the inlet and outlet ports.

## Introduction

According to the sealing performance, pneumatic butterfly valve can be divided into metal seal and soft seal type. Advantages pneumatic butterfly valve over other type valves may include: compact structure, miniature size, long service life, good sealing performance, easy maintenance, quick detachable and installation.

## Pneumatic Actuator

Double acting	Air to open, air to close, air supply failure to keep the current position
Single Acting N/C	Air to open, interrupt air to close, air failure to close
Single Acting N/O	Air to close, interrupt air to open, air failure to open
Optional accessory	Reversing solenoid valve, limit switch box, air filter reducing valve, positioner, handle manual, lock up valve



## Technical Parameters

Body		Valve components	
Size Range	DN50-DN600	Seating Material	NBR, EPDM, VITON, PTFE
Body material	SS, CI, Ductile Iron, WCB	Disc Material	Stainless Steel
End Connection	Wafer Flange	Stem Material	Stainless Steel
Operating Pressure	< 1.6MPa	Applicable media	Control of Water, Air, Gas, Oil, Liquid, Steam
Structure	Midline Structure / A-type		

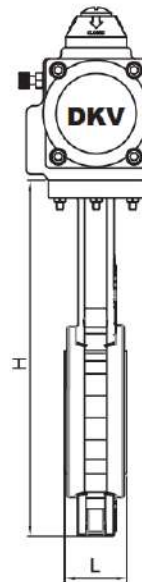

## Qutine Size drawing

UNIT: mm

MEDLE	DN50	DN65	DN80	DN100	DN125	DN150	DN200	DN250	DN300	DN350	DN400	DN500
Inch	2"	2-1/2"	3"	4"	5"	6"	8"	10"	12"	14"	16"	20"
D	52.7	64.4	78.8	104.2	123.3	157	202.5	250.5	301.6	333.3	389.6	491.6
D1	89	104	127	153	180	206	270	320	368	428	482	605
D2	125	145	160	180	210	240	295	355	410	470	525	585
L	41.4	44	45	52	54	54	55	60	65	76	86	130
H	217	234	252	289	318	341	428	490	567			
n-φd	4-M16	4-M16	8-M16	8-M16	8-M16	8-M20	12-M20	12-M24	12-M24			
Actuator	AT52	AT52	AT63	AT75	AT83	AT92	AT115	AT125	AT140			

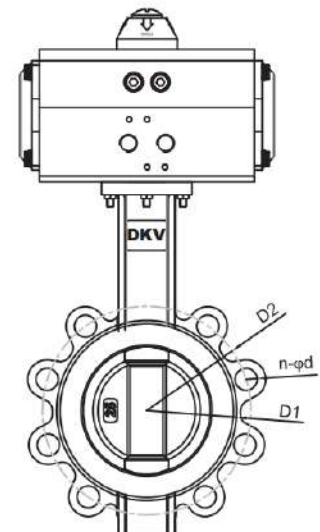

## Maintenance

- Tightening the seal between the valve and the actuator:  
Remove the four bolts underneath the actuator. Separate the actuator from the valve.  
Tighten the nut on the top of the valve body.  
Place the actuator back on the valve and screw everything back into place.
- Tightening the seals between the valve and the inlet/outlet ports:  
Remove the torque bolts and check for any debris or damage to the gaskets.  
Use a torque wrench or other consistent method of tightening the torque bolts to reconnect the inlet and outlet ports.



### Introduction

According to the sealing performance, pneumatic butterfly valve can be divided into metal seal and soft seal type. Advantages pneumatic butterfly valve over other type valves may include: compact structure, miniature size, long service life, good sealing performance, easy maintenance, quick detachable and installation.

### Pneumatic Actuator

Double acting	Air to open, air to close, air supply failure to keep the current position
Single Acting N/C	Air to open, interrupt air to close, air failure to close
Single Acting N/O	Air to close, interrupt air to open, air failure to open
Optional accessory	Reversing solenoid valve, limit switch box, air filter reducing valve, positioner, handle manual, lock up valve



### Technical Parameters

Body		Valve components	
Size Range	DN50-DN600	Seating Material	NBR, EPDM, VITON, PTFE
Body material	SS, CI, Ductile Iron, WCB	Disc Material	Stainless Steel
End Connection	Flange	Stem Material	Stainless Steel
Operating Pressure	PN10	Applicable media	Control of Water, Air, Gas, Oil, Liquid, Steam
Structure	Midline Structure / A-type		

### Qutine Size drawing

UNIT: mm

MEDLE	DN50	DN65	DN80	DN100	DN125	DN150	DN200	DN250	DN300	DN350	DN400	DN500	Dn600
Inch	2"	2-1/2"	3"	4"	5"	6"	8"	10"	12"	14"	16"	20"	24"
D	52.7	64.4	83	104.2	123.3	157	202.5	250.5	301.6	333.3	389.6	491.6	592.5
D1	165	185	200	220	250	285	340	395	445	505	565	670	780
D2	125	145	160	180	210	240	295	355	410	470	525	620	725
D3	99	118	132	156	184	211	266	319	370	429	480	582	
L	108	112	114	127	140	140	150	165	185	195	216	229	267
H	198	218	233	267	303	335	400	465	535	598	709	841	1019
n-φd	4-φ19	4-φ19	8-φ19	8-φ19	8-φ189	8-φ23	8-φ23	12-φ23	12-φ223	16-φ23	16-φ28	20-φ28	20-φ31

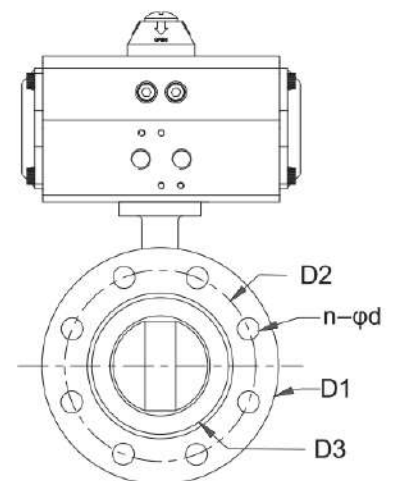
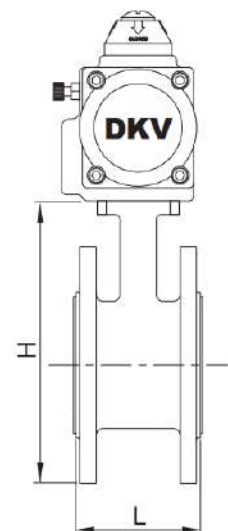

### Maintenance

- Tightening the seal between the valve and the actuator:**  
 Remove the four bolts underneath the actuator. Separate the actuator from the valve.  
 Tighten the nut on the top of the valve body.  
 Place the actuator back on the valve and screw everything back into place.
- Tightening the seals between the valve and the inlet/outlet ports:**  
 Remove the torque bolts and check for any debris or damage to the gaskets.  
 Use a torque wrench or other consistent method of tightening the torque bolts to reconnect the inlet and outlet ports.

## Introduction

Fluorine lined butterfly valve is in the conventional butterfly valve and valve plate lined with teflon, so that the media and valve body isolation, antiseptic effect. The valve has more and more close closure function, sealing performance is reliable. Applicable to any concentration of acid, alkali, salt and oxidative extrusion, reducing agent, organic solvents and other media.

## Pneumatic Actuator

Double acting	Air to open, air to close, air supply failure to keep the current position
Single Acting N/C	Air to open, interrupt air to close, air failure to close
Single Acting N/O	Air to close, interrupt air to open, air failure to open
Optional accessory	Reversing solenoid valve, limit switch box, air filter reducing valve, positioner, handle manual, lock up valve



## Technical Parameters

Body		Valve components	
Size Range	DN50-DN600	Seating Material	PTFE
Body material	SS, CI, Ductile Iron, WCB	Disc Material	Stainless Steel
End Connection	Wafer Flange	Stem Material	Stainless Steel
Operating Pressure	<1.6MPa	Applicable media	Control of Water, Air, Gas, Oil, Liquid, Steam
Structure	Midline Structure / A-type		

## Outline Size drawing

UNIT: mm

MEDLE	DN50	DN65	DN80	DN100	DN125	DN150	DN200	DN250	DN300	DN350	DN400	DN500
Inch	2"	2-1/2"	3"	4"	5"	6"	8"	10"	12"	14"	16"	20"
D	50	65	80	100	125	150	200	250	300	350	400	500
D1	96	104	127	153	180	206	270	320	368	428	482	605
D2	125	145	160	180	210	240	295	355	410	470	525	585
L	43	46	46	52	56	56	60	68	78	78	102	127
L1	108	112	114	127	140	140	152	165	178	190	216	229
H	212	230	233	270	298	337	407	480	555	610	715	870
n-φd	4-φ18	4-φ18	8-φ18	8-φ18	8-φ18	8-φ23	8-φ23	12-φ23	12-φ23	16-φ23	16-φ25	20-φ25
Actuator	AT52	AT52	AT63	AT75	AT83	AT92	AT115	A125	AT140			

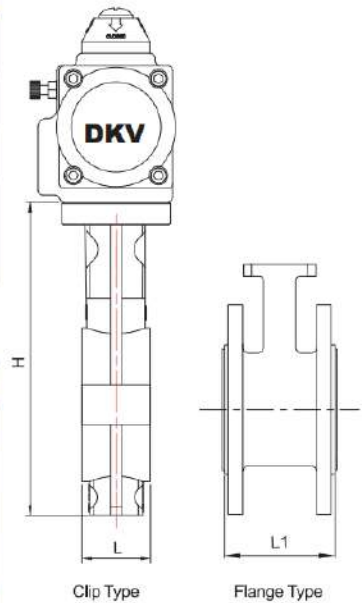

## Maintenance

- Tightening the seal between the valve and the actuator:**  
 Remove the four bolts underneath the actuator. Separate the actuator from the valve.  
 Tighten the nut on the top of the valve body.  
 Place the actuator back on the valve and screw everything back into place.
- Tightening the seals between the valve and the inlet/outlet ports:**  
 Remove the torque bolts and check for any debris or damage to the gaskets.  
 Use a torque wrench or other consistent method of tightening the torque bolts to reconnect the inlet and outlet ports.

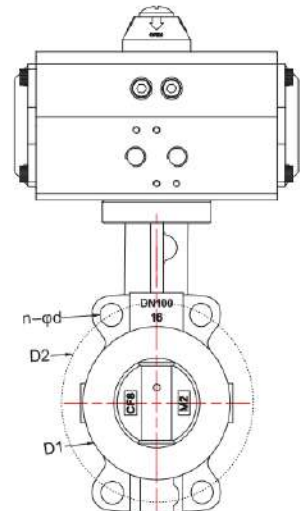



## Introduction

Sanitary pneumatic butterfly valves has been through the sophisticated inspection process and strict quality management. Using internal and external polishing and sterilization. Clamp quick connection, all-inclusive seal, easy to disassemble, cleaning and maintenance. They can be manually operated or automated with an electric or pneumatic actuator.

## Pneumatic Actuator

Double acting	Air to open, air to close, air supply failure to keep the current position
Single Acting N/C	Air to open, interrupt air to close, air failure to close
Single Acting N/O	Air to close, interrupt air to open, air failure to open
Optional accessory	Reversing solenoid valve, limit switch box, air filter reducing valve, positioner, handle manual, lock up valve



## Technical Parameters

Body		Valve components	
Nominal Size	DN15~DN100	Seat Material	PTFE: -30℃~180℃ PPL: -30℃~250℃
Body Material	SS304, SS316, SS316L	Disc Material	SS304, SS316, SS316L
Connection Type	Clamp, Welding	Stem Material	SS304,
Pressure Rating	PN1.6MPa	Design Standard	ISO、DIN、IDF、SMS、3A
Structure type	Midline Structure	Applicable Medium	Food, Medicine, Packaging Machinery, Filling Machinery And Other Health Conditions Using Level.

## Qutine Size Drawing

Size	Ø19	Ø25	Ø32	Ø38	Ø51	Ø63	Ø76	Ø89	Ø102
	DN15	DN20	DN25	DN32	DN40	DN50	DN65	DN80	DN100
d	16	21	29	35	47	59	72	85	97
D	50.5	50.5	50.5	50.5	64	77.5	91	106	119
L	68	68	68	72	72	72	81	82.5	85
H	99	99	99	114	125	140	150	165	180
Weight (Kg)	2.78	2.78	2.78	3.28	4.28	5.08	6.18	9.08	10.5
Actuator	AT52		AT63		AT75	AT83	AT92	AT105	AT115

UNIT: mm

## Maintenance

- Tightening the seal between the valve and the actuator:  
Remove the four bolts underneath the actuator. Separate the actuator from the valve.  
Tighten the nut on the top of the valve body.  
Place the actuator back on the valve and screw everything back into place.
- Tightening the seals between the valve and the inlet/outlet ports:  
Remove the torque bolts and check for any debris or damage to the gaskets.  
Use a torque wrench or other consistent method of tightening the torque bolts to reconnect the inlet and outlet ports.

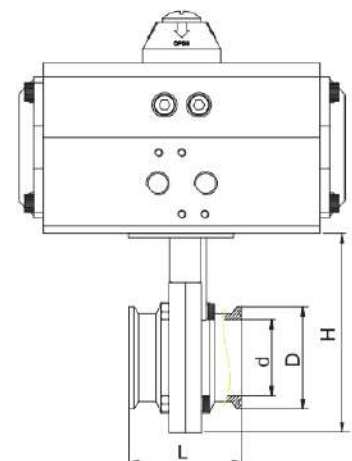

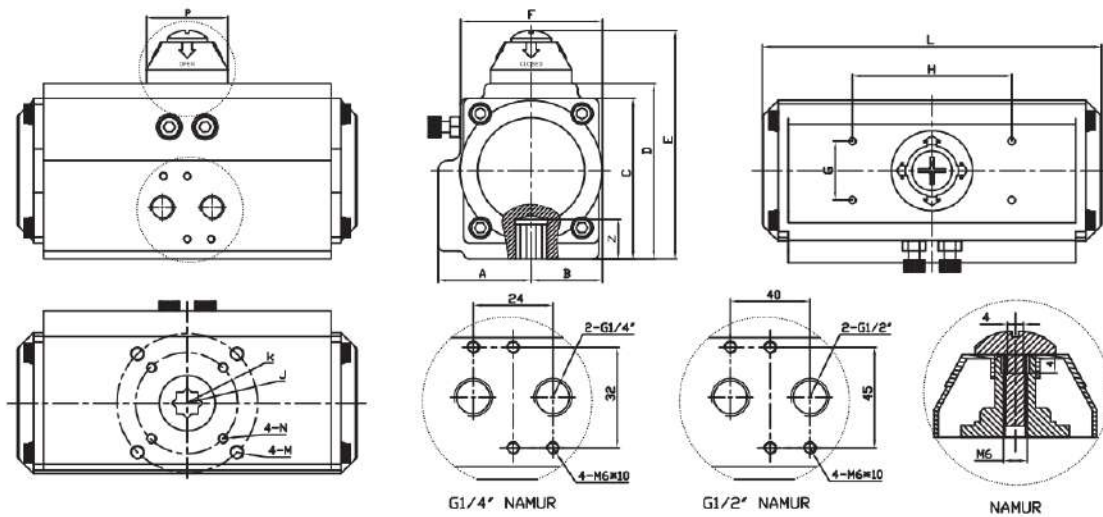

### Introduction

1. Operating media: Dry or lubricated air, or the non-corrosive gases The maximum particle diameter must less than 30 u m
2. Air supply pressure: The minimum supply pressure is 2,5 Bar The maximum supply pressure is 8 Bar
3. Operating temperature: Standard:  $-20^{\circ} \text{ c} \rightarrow 80^{\circ} \text{ c}$  Low temperature:  $-35^{\circ} \text{ c} \sim +80^{\circ} \text{ c}$  High temperature:  $-15^{\circ} \text{ c} \sim M50^{\circ} \text{ c}$
4. Travel adjustment: Have adjustment range of  $\pm 5^{\circ}$  for the rotation at  $0^{\circ}$  and  $90^{\circ}$

### Outline Size drawing

MODEL	A	B	C	D	E	F	G	H	J	K	N	M	L	P	Z	Air Hole
AT52	30	42.5	65.5	72.4	92.5	50.5	30	80	∅36	∅50	M5×8	M6×10	150	42	14	NAMUR G1/4"
AT63	36	47	81	88.5	98.5	69.5	30	80	∅50	∅70	M6×10	M8×13	171	42	18	NAMUR G1/4"
AT75	42.5	53	93	100	120	78	30	80	∅50	∅70	M6×10	M8×13	186	42	18	NAMUR G1/4"
AT83	46.5	57	98.5	109.7	129.5	86	30	80	∅50	∅70	M6×10	M8×13	206	42	21	NAMUR G1/4"
AT92	50	58	106	117	137	90	30	80	∅50	∅70	M6×10	M8×13	265	42	21	NAMUR G1/4"
AT105	57.5	64	122.5	135	155	104.5	30	80	∅70	∅102	M8×13	M10×16	272	42	27	NAMUR G1/4"
AT125	67.5	74.5	145.5	157	177	120.5	30	80	∅70	∅102	M8×13	M10×16	304	60	27	NAMUR G1/4"
AT140	75.5	75.5	161	174	194	125	30	80	∅102	∅125	M10×16	M12×20	395	60	32	NAMUR G1/4"
AT160	87	87	184	198	228	143	30	80	∅102	∅125	M10×16	M12×20	462	60	32	NAMUR G1/4"
AT190	103	103	216	232	262	172	30	130	∅102	∅140	M10×16	M16×25	520	85	40	NAMUR G1/4"
AT210	113	113	235.5	257	287	194	30	130	∅102	∅140	M10×16	M16×25	538	85	40	NAMUR G1/4"
AT240	130	130	235.5	292	322	230	30	130		∅165		M20×30	592	90	50	NAMUR G1/4"
AT270	147	147	235.5	331	361	253	30	130		∅165		M20×30	713	90	50	NAMUR G1/2"
AT300	161	168	235.5	354	384	290	30	130	∅165	∅215	M20×30	M20×30	771	90	50	NAMUR G1/2"

### Common faults and inspection, troubleshooting

Failure Phenomenon	Inspection Items	Solution
Pneumatic Valve Can Not Move	The electromagnetic valve is normal, Coil is burned, electromagnetic valve Is stuck being stolen	Solenoid valve replacement, Replacement coils, remove stolen Property.
	A separate air supply pneumatic Actuator test check seals and Whether the cylinder is damaged.	Replace a bad ring and cylinder.
	There are impurities in the spool Valve stuck.	Remove impurities, replace Damaged parts.
	the handle in a manual hand motor location.	Interchange
Slow Motion, Crawling	Supply pressure is not enough.	The increase of gas supply pressure(0.4–0.7mpa)
	Pneumatic actuator outputtorque is Too small.	Increase the pneumatic actuator Production.
	The valve spool or valve assembly too tight.	Re-assembly adjustments.
	Air supply pipe plug, flow is toosmall.	Exclude plug, replace the filter cartridge.
Reply Devices Without Signal	power line short circuit or open circuit.	Maintenance of power lines.
	reply within the cam position is not accurate.	Adjust the cam to the correct location
	Micro switch damaged.	Replacement micro switch



## PNEUMATIC VALVE



## ELECTRIC VALVE



**Pipeline system overall solution**